

INSTALLATION OPERATION MAINTENANCE

YCZ-IOM-1F
18-EB21D4-7

Library	Service Literature
Product Section	Unitary
Product	Packaged Gas/Electric
Model	YCZ
Literature Type	Installation, Operation, Maintenance
Sequence	1F
Date	December 2002
File No.	SV-UN-RT-YCZ-IOM-1F 12/02
Supersedes	New

ALL phases of this installation must comply with
NATIONAL, STATE AND LOCAL CODES

Model:

YCZ036F1/3M0B, 4MOA
YCZ050F1/3HOA, 4H0A
YCZ060F1/3M0B, 4M0A
BAYLIFT002A
LIFTING LUG KIT

Single Package Two Stage Gas/Electric 16 SEER Convertible 3, 4, 5 Ton

IMPORTANT — This Document is customer property and is to remain with this unit. Please return to service information pack upon completion of work.

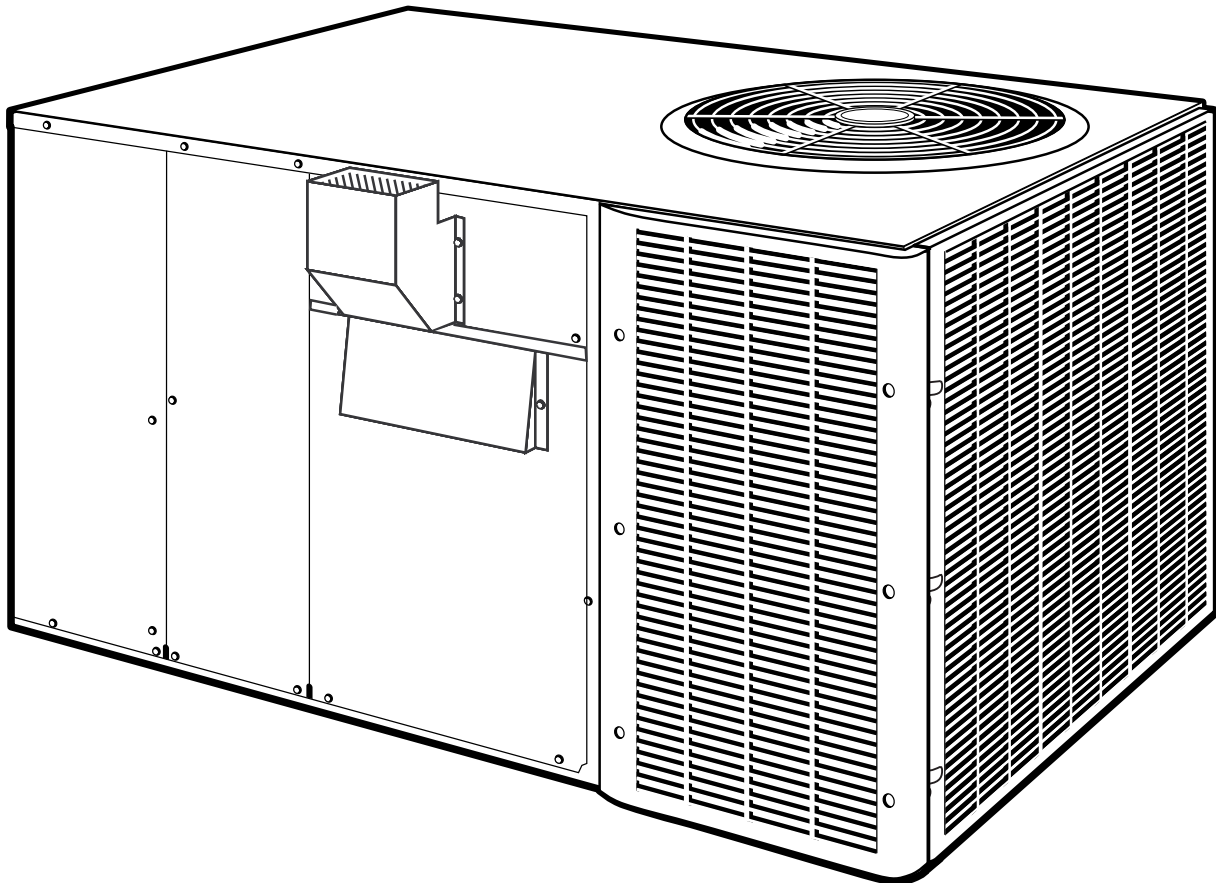

⚠ WARNING: HAZARDOUS VOLTAGE - DISCONNECT POWER BEFORE SERVICING

All phases of this installation must comply with the **NATIONAL, STATE & LOCAL CODES**. In the absence of local codes, the installation must conform with **National Electric Code -- ANSI/NFPA 70** or "**LATEST REVISION**."

Since Trane has a policy of continuous product and product data improvement, it reserves the right to change design and specification without notice.

© 2002 American Standard Inc. All rights reserved

12/02

GENERAL INFORMATION

IMPORTANT: Read this entire manual before beginning installation procedures.

⚠ WARNING: BODILY INJURY CAN RESULT FROM HIGH VOLTAGE ELECTRICAL COMPONENTS, FAST MOVING FANS, AND COMBUSTIBLE GAS. FOR PROTECTION FROM THESE INHERENT HAZARDS DURING INSTALLATION AND SERVICING, THE ELECTRICAL SUPPLY MUST BE DISCONNECTED AND THE MAIN GAS VALVE MUST BE TURNED OFF. IF OPERATING CHECKS MUST BE PERFORMED WITH THE UNIT OPERATING, IT IS THE TECHNICIANS RESPONSIBILITY TO RECOGNIZE THESE HAZARDS AND PROCEED SAFELY.

Read this manual carefully before attempting to install, operate, or perform maintenance on this unit. Installation and maintenance should be performed by qualified service technicians only.

As shipped from the factory, this unit is for use with natural gas only, and is listed by Underwriters Laboratory.

Model YCY-F heating/cooling units are designed for outdoor mounting with a vertical condenser discharge. They can be located either at ground level or on a roof, in accordance with local codes or National Fuel Gas Code (ANSI-Z223.1A) Latest Revision. Since these units are designed exclusively for outdoor operation, additional flue venting systems are not required. Each unit contains an operating charge of Refrigerant-22 as shipped.

INSPECTION

1. Check for damage after the unit is unloaded. Report promptly, to the carrier, any damage found to the unit. Do not drop the unit.

IMPORTANT: The use of "spreader bars" is required when hoisting the unit (to prevent damage to sides and top).

2. Check the unit's nameplate to determine if the unit is correct for the intended application. The power supply must be adequate for both the unit and all accessories.
3. Check to be sure the refrigerant charge has been retained during shipment. Access to 1/4" flare pressure taps may be gained by removing the furnace compartment access panel.

IMPORTANT: DO NOT CONNECT GAS PIPING TO THE UNIT UNTIL A LINE PRESSURE TEST HAS BEEN COMPLETED. DAMAGE TO THE GAS VALVE MAY RESULT IN AN UNSAFE CONDITION. THIS UNIT SHOULD NEVER BE EXPOSED TO GAS LINE PRESSURE IN EXCESS OF 14 INCHES WATER COLUMN. (1/2 PSIG)

IMPORTANT: RECONNECT ALL GROUNDING DEVICES. ALL PARTS OF THIS PRODUCT CAPABLE OF CONDUCTING ELECTRICAL CURRENT ARE GROUNDED. IF GROUNDING WIRES, SCREWS, STRAPS, CLIPS NUTS OR WASHERS USED TO COMPLETE A PATH TO GROUND ARE REMOVED FOR SERVICE, THEY MUST BE RETURNED TO THEIR ORIGINAL POSITION AND PROPERLY FASTENED.

IMPORTANT: ALL POWER LEGS MAY NOT BE BROKEN BY CONTACTORS. SEE WIRING DIAGRAM ON UNIT CONTROL BOX COVER.

THIS UNIT, AS SHIPPED FROM THE FACTORY, IS DESIGNED FOR NATURAL GAS ONLY.

BEFORE STARTING THE COMPRESSOR, THE CRANKCASE HEATER SHOULD BE ENERGIZED FOR EIGHT HOURS

The following warning complies with State of California law, Proposition 65.

⚠ WARNING: Hazardous Gasses!
Exposure to fuel substances or by-products of incomplete fuel combustion is believed by the state of California to cause cancer, birth defects, or other reproductive harm.

NOTICE

Warnings and Cautions appear at appropriate locations throughout this manual.
Read these carefully.

⚠ WARNING: Indicates a potentially hazardous situation which, if not avoided, could result in death or serious injury.

⚠ CAUTION: Indicates a potentially hazardous situation which, if not avoided, may result in minor or moderate injury. It may also be used to alert against unsafe practices and where property-damage-only accidents could occur.

1

TYPICAL ROOFTOP INSTALLATION WITH FULL PERIMETER CURBS (YCZ036,050,060F Models)

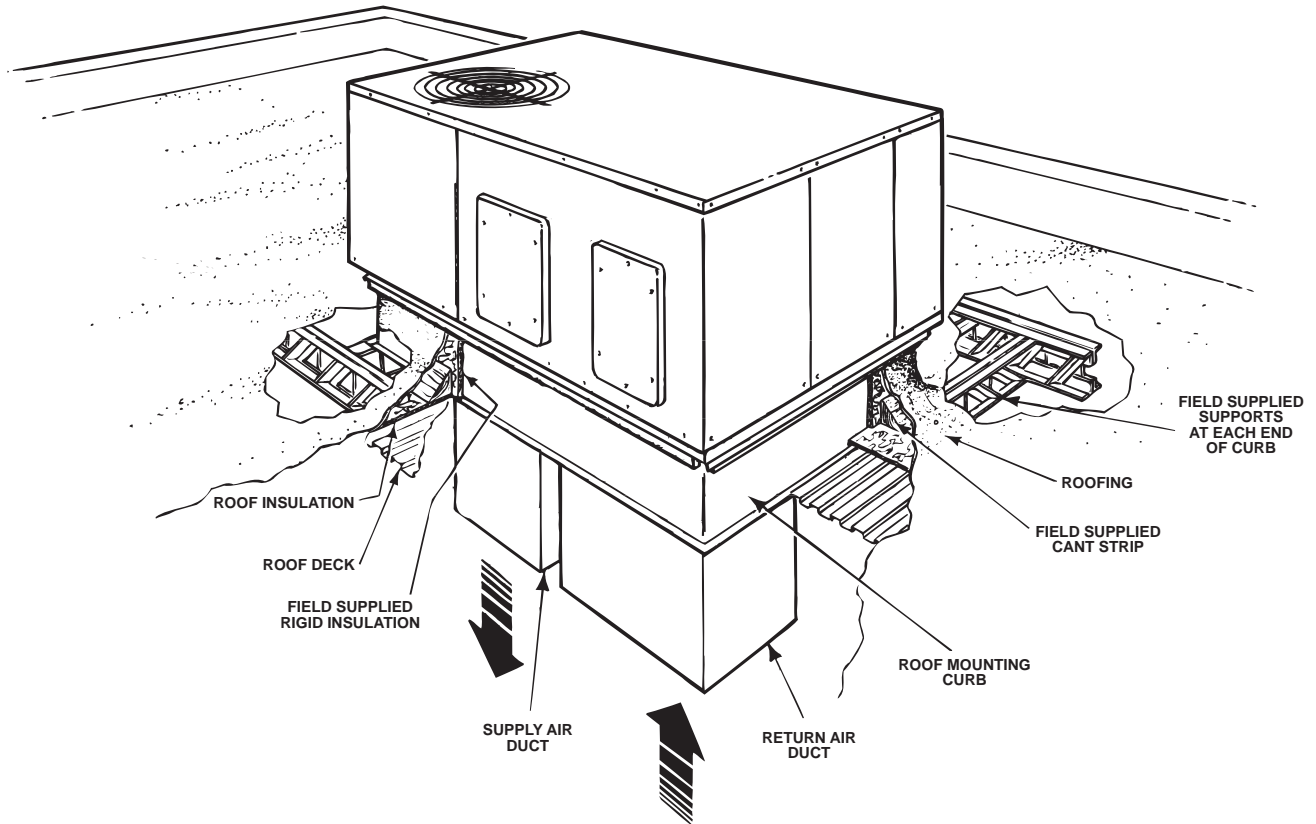

2

TYPICAL ROOFTOP INSTALLATION WITH BAYCURB030A,038A (YCZ036,050,060F Models)

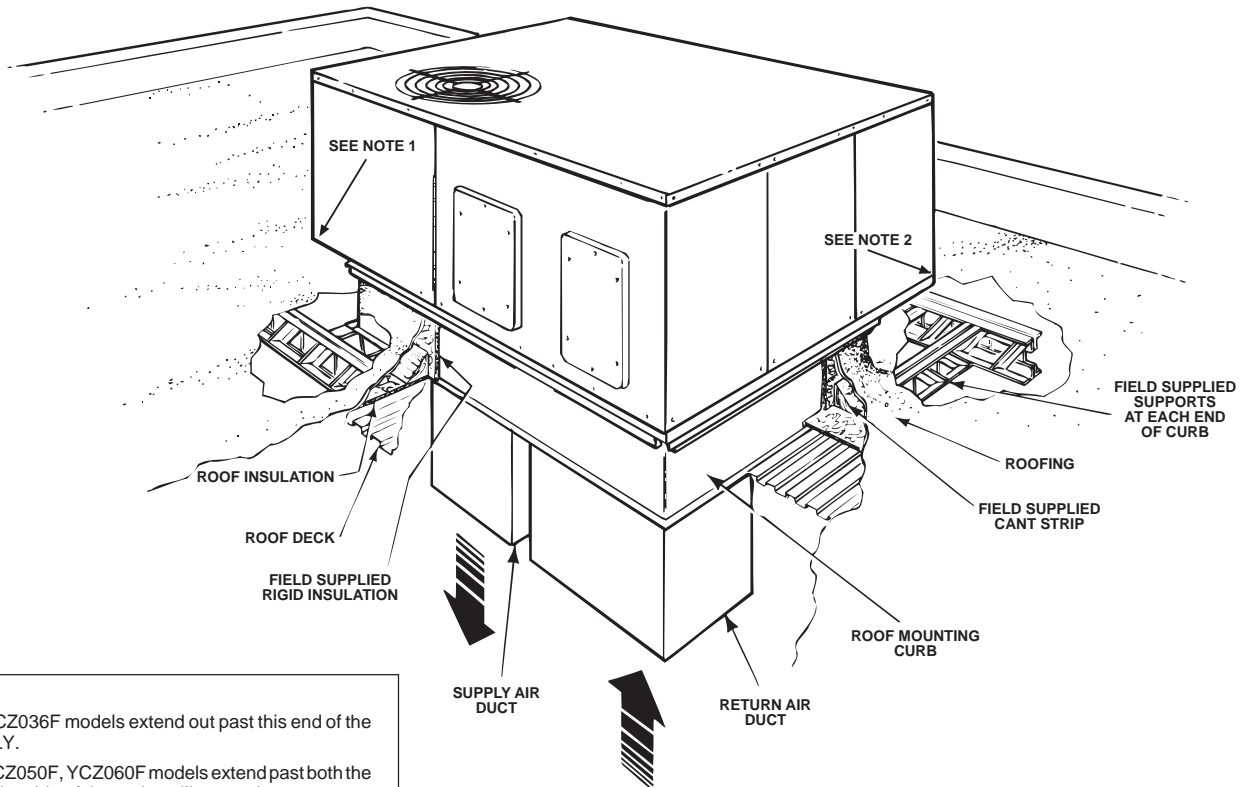

NOTES:

- 1. The YCZ036F models extend out past this end of the curb ONLY.
- 2. The YCZ050F, YCZ060F models extend past both the end and the side of the curb as illustrated.

DIMENSIONAL DATA

3

YCZ036,050,060F OUTLINE – BACK

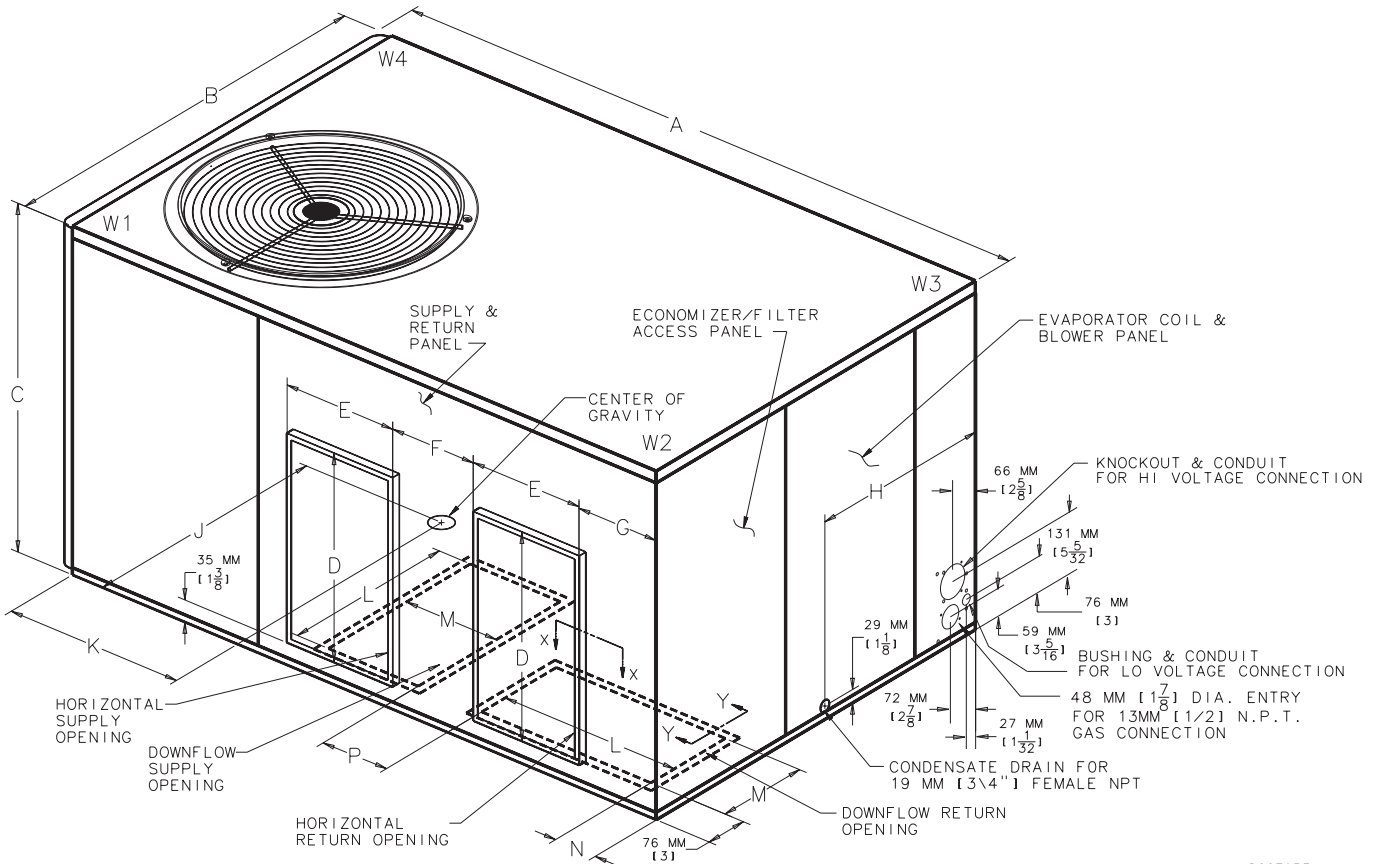

D667953

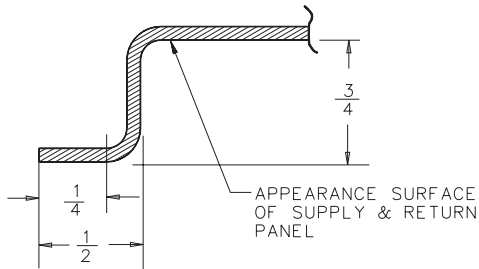

SECT. X-X

TYPICAL CROSS SECTION OF SUPPLY & RETURN PERIMETER FLANGES

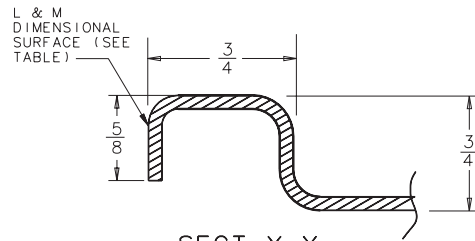

SECT Y-Y

TYPICAL CROSS SECTION OF DOWNFLOW SUPPLY & RETURN PERIMETER FLANGES

MODEL	CORNER WEIGHT (LBS)				NET UNIT WEIGHT (LBS)	A	B	C	D	E	F	G	H	J	K	L	M	N	P
	W1	W2	W3	W4															
YCZ036F	161	106	104	157	528	64	36	29-3/16	18-9/16	11-1/16	6-9/16	11-1/8	17	18-1/2	25-1/2	17-1/2	10	3	8-3/4
YCZ050F	172	121	137	196	626	65-1/8	45	33-3/8	21-1/16	15-1/16	4-15/16	9-1/8	21-15/16	24	26-1/2	20	14	3-1/2	8-5/16
YCZ060F	195	129	132	199	656									22-3/4	25-1/2				

DIMENSIONAL DATA

4

YCZ036,050,060F OUTLINE – FRONT

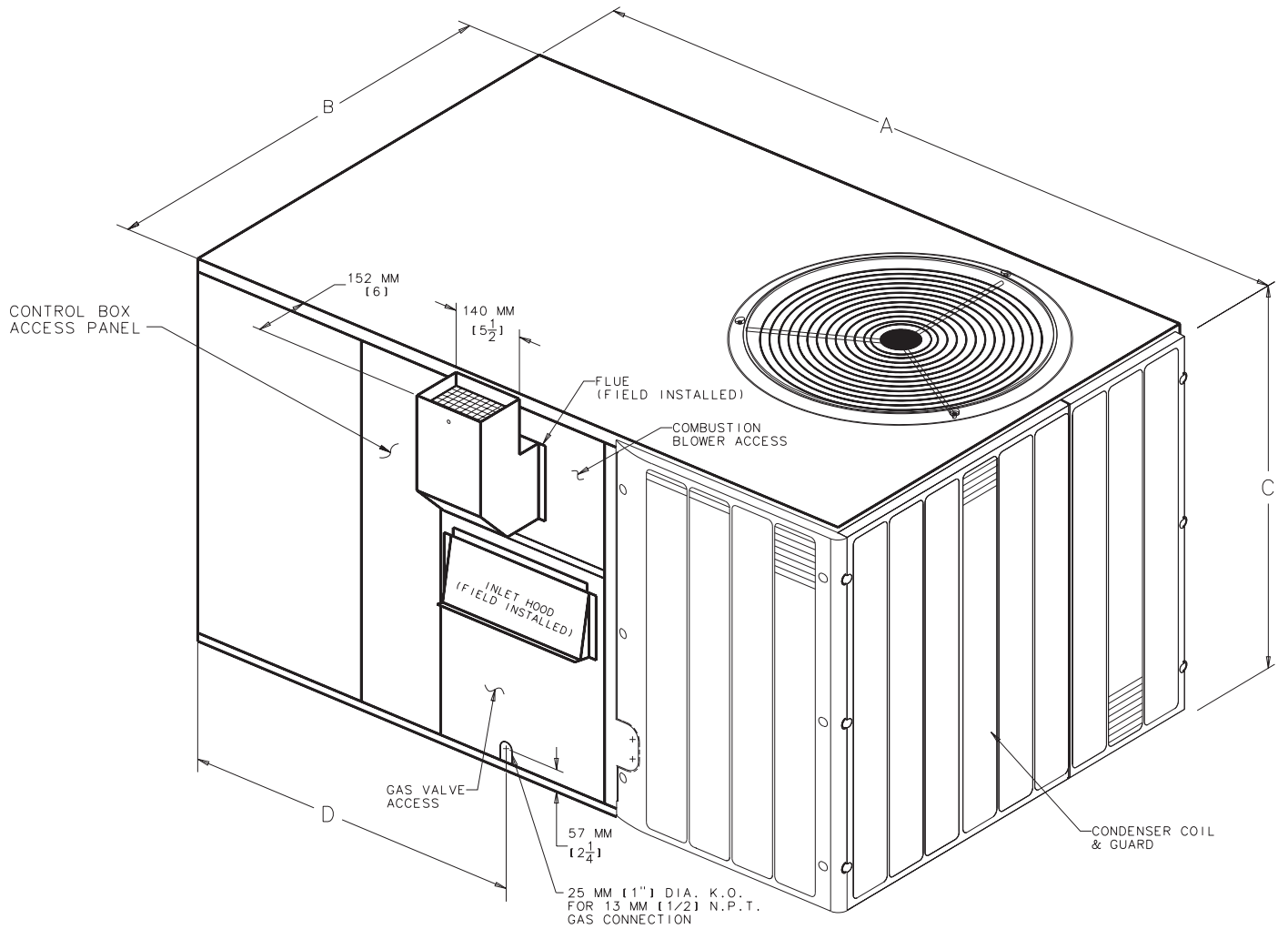

D667952

RECOMMENDED SERVICE CLEARANCE	
BACK	* 6.0"
LEFT SIDE	30.0"
RIGHT SIDE	24.0"
FRONT	42.0"

* 18" WITH FRESH AIR ACCESSORY
* 30" WITH ECONOMIZER

CLEARANCE TO COMBUSTIBLE MATERIAL	
BOTTOM	0.0"
BACK	1.0"
LEFT SIDE	6.0"
RIGHT SIDE	6.0"
FRONT SIDE	12.0"
TOP	36.0"

MODEL	A	B	C	D
YCZ036F-M	64	36	29-3/16	27-1/2
YCZ050F-M YCZ060F-M	65-1/8	45	33-3/8	27-15/16

5

CONVERTING HORIZONTAL TO DOWNFLOW

NOTE

SUPPLY OPENING

1. REMOVE SCREW NEAREST TO THE OPENING AND PULL THE PANEL FIRMLY TOWARD THE OUTSIDE OF THE UNIT TO DISENGAGE THE BACK ATTACHMENT.

RETURN OPENING

2. REMOVE RIGHT HAND SCREW AND MOVE PANEL TO THE RIGHT OR REMOVE BOTH SCREWS.

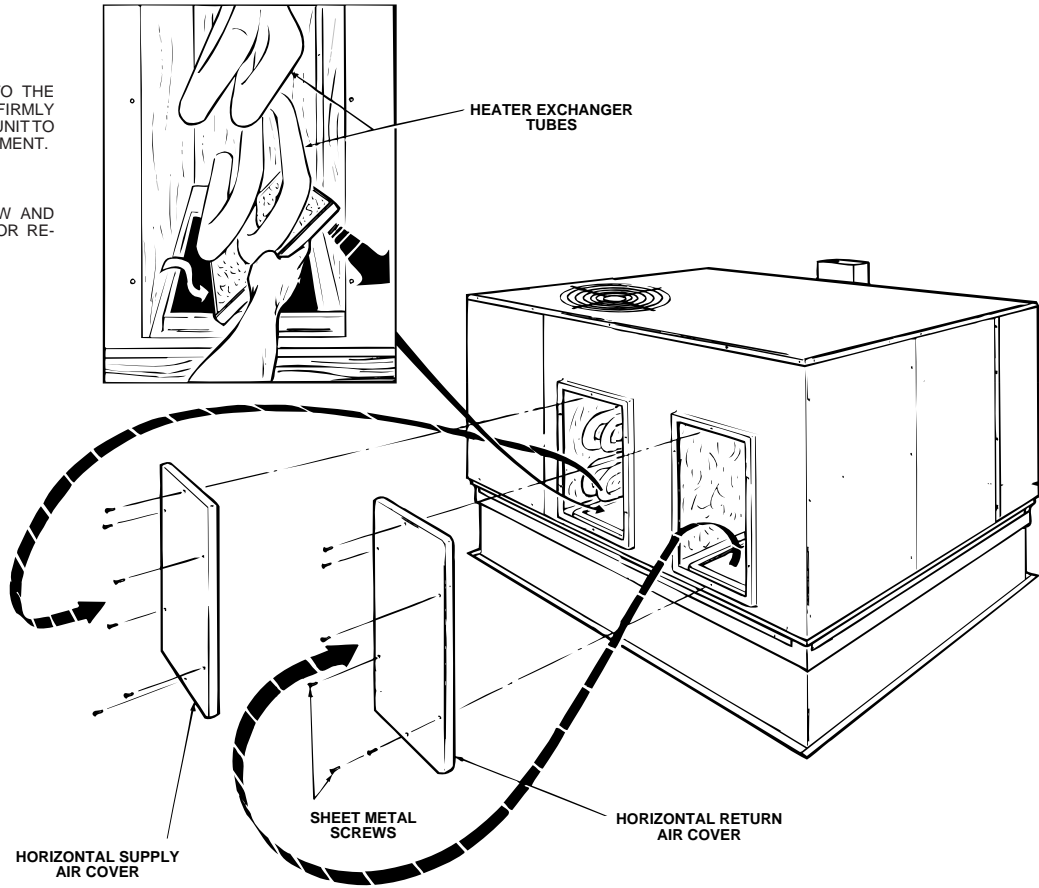

6

REQUIRED CLEARANCE FOR UNIT INSTALLATION AND ROOF PENETRATION HOLE SIZE REQUIRED

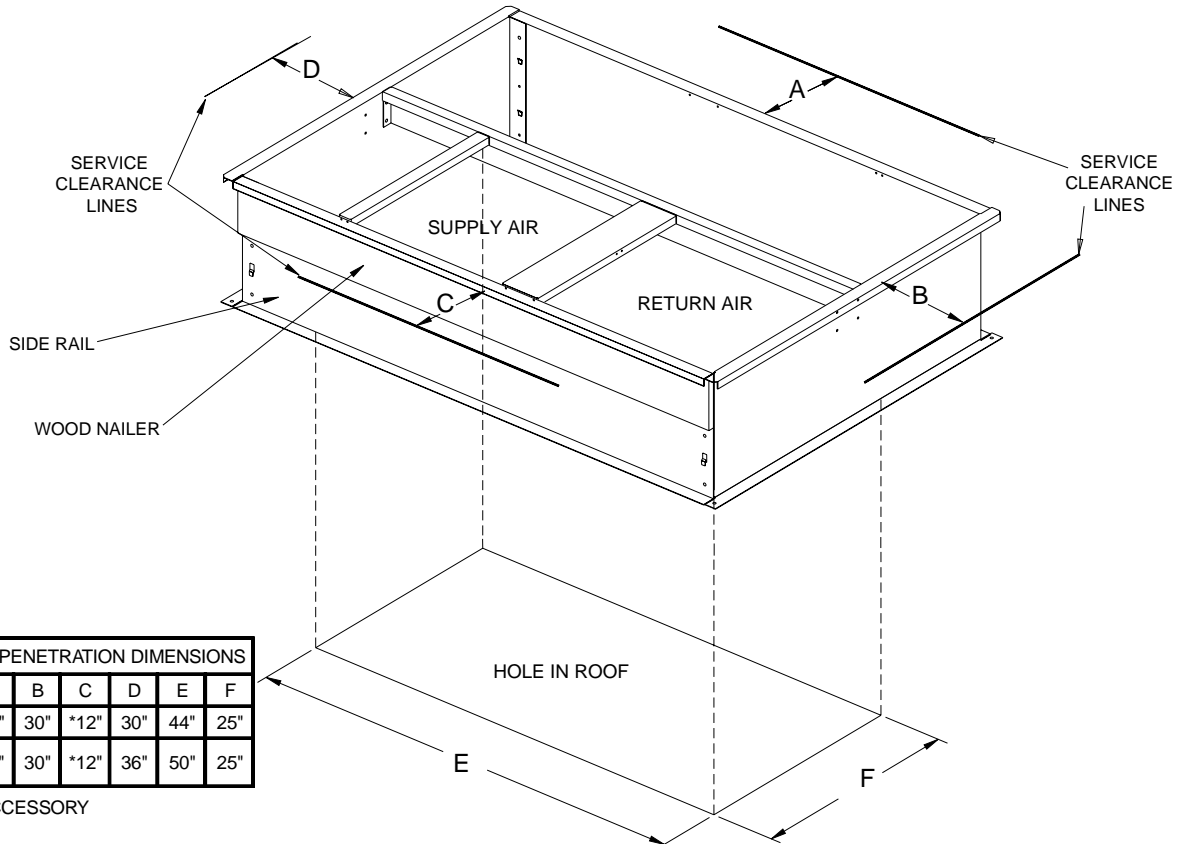

SERVICE CLEARANCE & PENETRATION DIMENSIONS						
MODEL NO.	A	B	C	D	E	F
YCZ036F	30"	30"	*12"	30"	44"	25"
YCZ050F YCZ060F	42"	30"	*12"	36"	50"	25"

* 18" WITH FRESH AIR ACCESSORY
* 30" WITH ECONOMIZER

LOCATIONS AND RECOMMENDATIONS

HORIZONTAL AIRFLOW APPLICATION

1. These units are design certified for outdoor installations. These units may be installed directly on wood flooring or on Class A, Class B, or Class C roof covering material. The discharge air from the condenser fans must be unrestricted for a minimum of 3 feet above the unit.

NOTE: *The unit is shipped for horizontal installation.*

The Air Inlet Hood in the combustion blower access panel must have adequate clearance around the air opening into the combustion area. See Outline Drawing, Figure 3.

Examine all flue product-carrying areas of the furnace, its vent system, and the main burner for safe operation. A periodic inspection of the furnace should be made by a qualified service agency at the start of each heating season.

Replacement parts list for this Gas/Electric Air Conditioner, may be obtained by contacting your local manufacturer representative.

NOTE: *If any internal accessories are to be added to the unit, install them at the shop if at all practical.*

2. Location of the unit must allow service clearance around it. Clearance of the unit must be given careful consideration. See Figures 2, 3, and 4.

IMPORTANT: Air outlet duct must have 1" clearance to combustible material downstream from the unit.

3. Check the handling facilities to ensure the safety of personnel and the unit(s).
4. **CAUTION MUST BE TAKEN AT ALL TIMES TO AVOID PERSONAL INJURIES AND/OR DAMAGE TO EQUIPMENT**
5. The unit must be mounted level for proper drainage of water through the holes in the base pan.
6. The unit must not be exposed to direct roof water runoff.
7. Flexible duct connectors must be of a flame retardant material. All duct work outside of the structure must be insulated and weatherproofed in accordance with local codes.
8. Holes through exterior walls must be sealed in accordance with local codes.
9. All fabricated outdoor ducts should be as short as possible.

CLEARANCES

1. The recommended clearances for single-unit installations are illustrated in Figure 4. These minimum requirements are not only an important consideration when determining unit placement, but they are also essential to ensure adequate serviceability, maximum capacity, and peak operating efficiency.
2. Any reduction of the unit clearances indicated in these illustrations may result in condenser coil starvation or the recirculation of warm condenser air. Actual clearances which appear to be inadequate should be reviewed with a local engineer.

3. See the unit's nameplate for the absolute minimum clearance between the unit and any combustible surface(s).

IMPORTANT:

1. Remove the Flue and Air Inlet Hood with gasket from the return air section of the unit.

The screws that attach the flue and air inlet hood will be installed in their proper location at the factory. Therefore, they must be removed and then used to attach the flue and the air inlet hood.

2. Remove the packaging material from the components and secure the Flue and Air Inlet Hood with the gasket to the unit with sheet metal screws as illustrated in Figure 5. See "Firing Rate Selection" section for additional information.

NOTE: *Outdoor air or other requirements during heating operation that result in supply air temperatures below 80 degrees F or return air temperatures below 50 degrees F may cause flue gas condensate to form and is to be avoided.*

DOWNFLOW APPLICATION -- CURB MOUNTING

1. The Roof Mounting Curb, (field assembled BAYCURB030,038,033,034A), or a field fabricated curb must be in place **before** the unit is hoisted to the roof top.
2. **The Roof Mounting Curb (frame) must be installed on a flat, level section of the roof (maximum of 1/4" per foot pitch) and provide a level mounting surface for the unit. In addition, be sure to provide sufficient height above the roof to prevent water from entering the unit.**

NOTE: *This unit was shipped for horizontal installation. Convert to downflow per instructions:*

Remove covers from the downflow supply and return air openings and place them over the horizontal supply return air openings (painted side out) and secure with sheet metal screws. See Figure 6.

3. Be sure the mounting curb spans structural members (trusses) of the roof, thereby providing sufficient support for the weight of the unit, the curb, the duct(s), and any factory or field installed accessories. See Figures 1, 7, 8, 9, 10, and 11.
4. Be sure the hole in the structure for the ducts is large enough to accommodate the fabricated ducts and the insulation surrounding them. See Figure 4.

Note: *If any internal accessories are to be added to the unit, install them at the shop if at all practical.*

5. These units are design certified for outdoor installation. These units may be installed directly on wood flooring or on Class A, Class B, or Class C roof covering material. The discharge air from the condenser fans must be unrestricted for a minimum of 3 feet above the unit.

The air inlet hood in the combustion blower access panel must have adequate clearance around air openings into the combustion area. See Outline Drawing, Figure 3.

continued on next page

LOCATIONS AND RECOMMENDATIONS

continued from page 7

Examine all flue product-carrying areas of the furnace, its vent system, and the main burner for safe operation. A periodic inspection of the furnace should be made at the start of each heating season.

Replacement parts list for this Gas/Electric Air Conditioner may be obtained by contacting your local manufacturer representative.

6. Location of the unit must allow for service clearance around it. Clearance of the unit must be given careful consideration. See Figure 4.
7. **IMPORTANT: The air outlet duct must have one (1) inch clearance to combustible material downstream from the unit.**
8. Exhaust vents or other sources of contaminated air should not be near the unit's air inlet, if outside air is to be introduced as make-up air or a ventilation feature is to be used.
9. Check the handling facilities to ensure the safety of personnel and the unit(s).
10. **Caution must be taken at all times to avoid personal injuries and/or damage to the equipment.**
11. The unit must be mounted level for proper drainage of water through the holes in the base pan.
12. The unit must not be exposed to direct roof water runoff.
13. Flexible duct connectors must be of a flame retardant material. All duct work outside of the structure must be insulated and weatherproofed in accordance with local codes.
14. Roof flashing must be installed to seal the roof curb cavity and must conform to local building codes.

15. Access and service clearances for the unit must be given careful consideration when locating the duct entrance openings. Figure 4 provides unit dimensions.
16. All fabricated outdoor ducts should be as short as possible.

CLEARANCES

1. The recommended clearances for single-unit installations are illustrated in Figure 4. These minimum requirements are not only an important consideration when determining unit placement, but they are also essential to ensure adequate serviceability, maximum capacity, and peak operating efficiency.
2. Any reduction of the unit clearances indicated in these illustrations may result in condenser coil starvation or the recirculation of warm condenser air. Actual clearances which appear to be inadequate should be reviewed with a local sales engineer.

IMPORTANT:

1. Remove the Flue and Air Inlet Hood with the gasket from the return air section of the unit.

The screws that attach the flue and air inlet hood will be installed in their proper location at the factory. Therefore, they must be removed and then used to attach the flue and air inlet hood.

2. Remove the packaging material from the components and secure the Flue and Air Inlet Hood with the gasket to the unit with sheet metal screws as illustrated in Figure 16 on page 14.

NOTE: Outdoor air or other requirements during heating operation that result in supply air temperatures below 80 degrees F or return air temperatures below 50 degrees F may cause flue gas condensate to form and is to be avoided.

INSTALLATION

UNIT SUPPORT

If the unit is to be roof mounted, check the appropriate building codes for weight distribution requirements. Refer to the applicable roof curb mounting instruction. Check the unit's nameplate for supply voltage required. Determine if adequate electrical power is available. The furnace may be installed on Class A, B, or C roofing material.

LOCATION AND CLEARANCES

Installation of the unit should conform to local building codes or, in the absence of local codes, to the National Fuel Gas Code, ANSIZ223.1, Latest Revision, and the National Electrical Code. Canadian installations must conform to CSA and local codes.

Select a location that will permit adequate combustion and ventilation air in accordance with Section 5.3, Air For Combustion and Ventilation, of the National Fuel Gas Code, ANSIZ223.1, Latest Revision, or applicable provisions of the local building code.

PLACING AND RIGGING

1. Before preparing the unit for lifting, check the outline drawing for center of gravity for lifting safety. Because of placement of internal components, the unit's weight may be unevenly distributed. Approximate unit weights are given in Figure 2, page 3.

NOTE: Accessory BAYLIFT002AA, a kit of four (4) lifting lugs, is required for rigging the unit for hoisting. See Figure 7, insert B.

2. Insert the four lifting lugs in the openings provided in the drip lip on the perimeter of the unit. See Figure 7, insert B. A tap or jerk to the lug will overcome the interference that arises due to the nipple on the lug.
3. Before hoisting the unit, be sure that the proper method of rigging is used, with straps or slings and spreader bars for protection during lifting. Always test-lift the unit to determine the exact unit balance and stability before hoisting it to the installation location.

INSTALLATION

IMPORTANT: Do not lift the unit without test lifting for balance and rigging. Do not lift the unit in windy conditions or above personnel. Do not lift the unit by attaching a clivus, hooks, pins, or bolts to the unit casing, casing hardware, corner lugs, angles, tabs, or flanges. Failure to observe these warnings may result in equipment damage.

4. When the curb and air ducts have been properly installed, the unit is ready to be hoisted to the roof and set in position.

IMPORTANT: "Spreader Bars" must be used when hoisting the unit.

5. **IMPORTANT:** The unit must be lowered into position. The P.V.C. rubber tape on the curb flange permits the unit to be repositioned if required without destroying the P.V.C. rubber seals affixed to the mounting curb.

PLACING THE UNIT ON A MOUNTING CURB

1. The unit is designed with a perimeter drip lip that is lower than the unit base bar, see Figure 7, inset A.
2. Position the unit drip lip down over and in contact with the outside corner of the curb, as illustrated in Figure 8, inset A. Continue to lower the unit on top of the curb, with the unit drip lip astraddle and in contact with both the end and side rail of the curb. The unit should now rest on top of the curb.
3. Take the two (2) hold-down brackets shipped with the curb and secure the unit to the curb with hold-down brackets as illustrated in Figure 8, inset A.

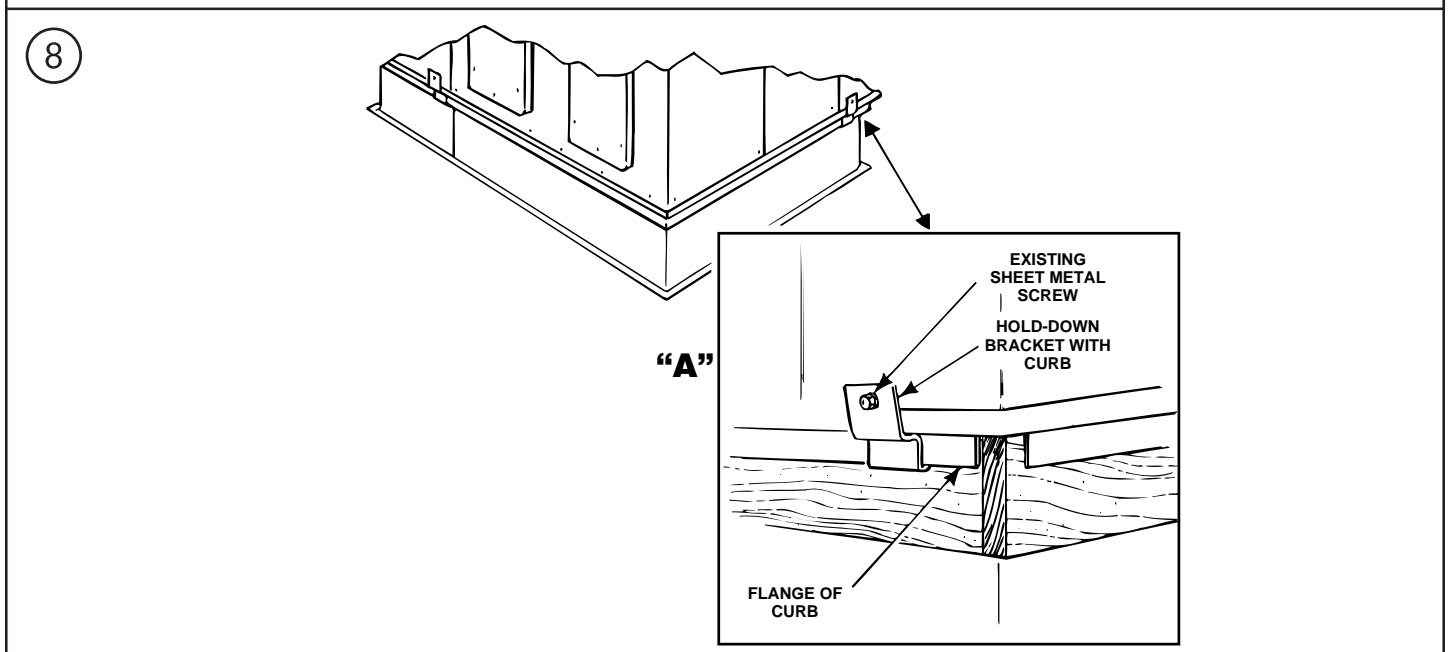
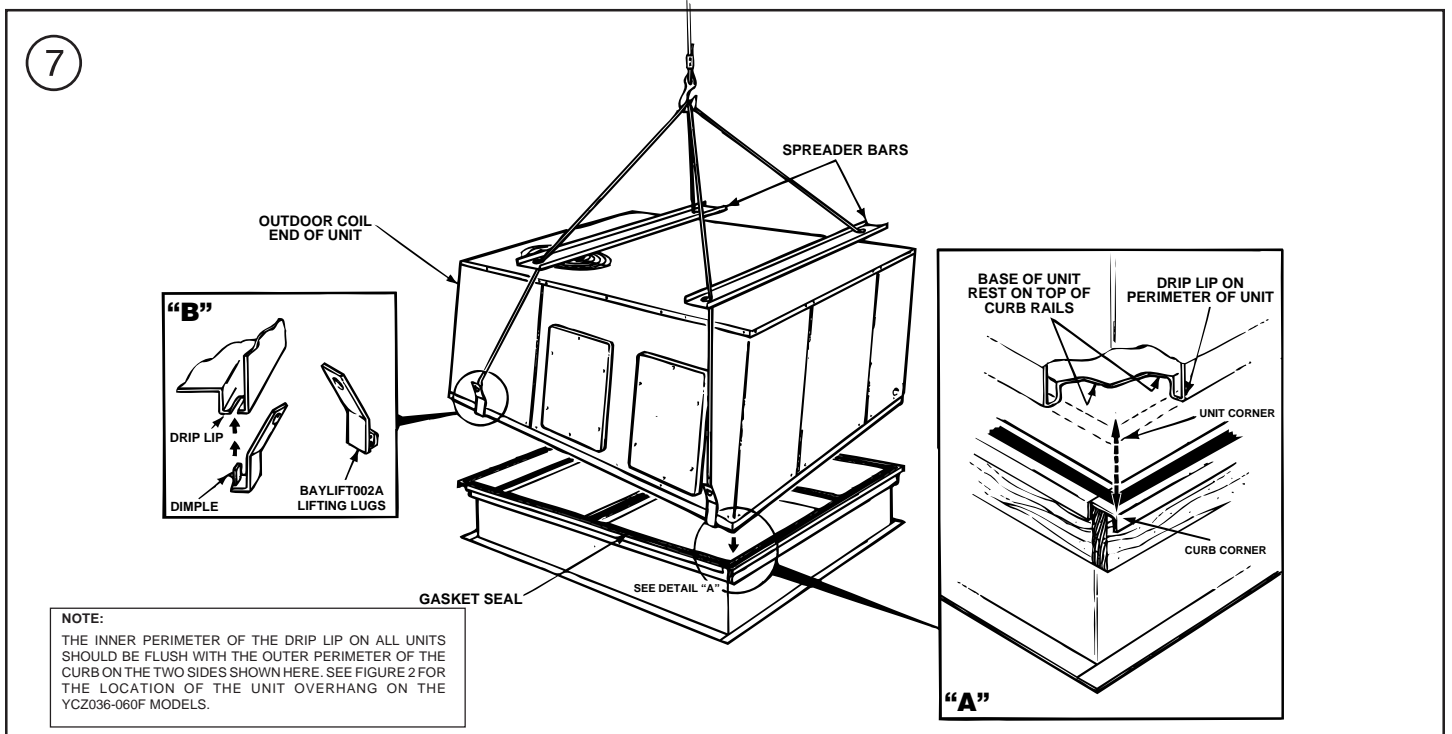

INSTALLATION

ROOFTOP -- UNITS

For roof top applications using a field fabricated frame and ducts, use the following procedure:

1. The frame must be located and secured by bolting or welding to the roof. Flashing is required.
2. The hole in the roof must be prepared in advance of installing the unit.
3. Secure the ducts to the roof.
4. Place the unit on the frame or roof curb. Refer to Figures 9 or 10.
5. Secure the unit to the frame or roof curb.
6. Insulate any ductwork outside of the structure with at least two (2) inches of insulation and then weatherproof. There must be a weatherproof seal where the duct enters the structure.
7. Complete the installation according to the instructions in the following sections of this manual.

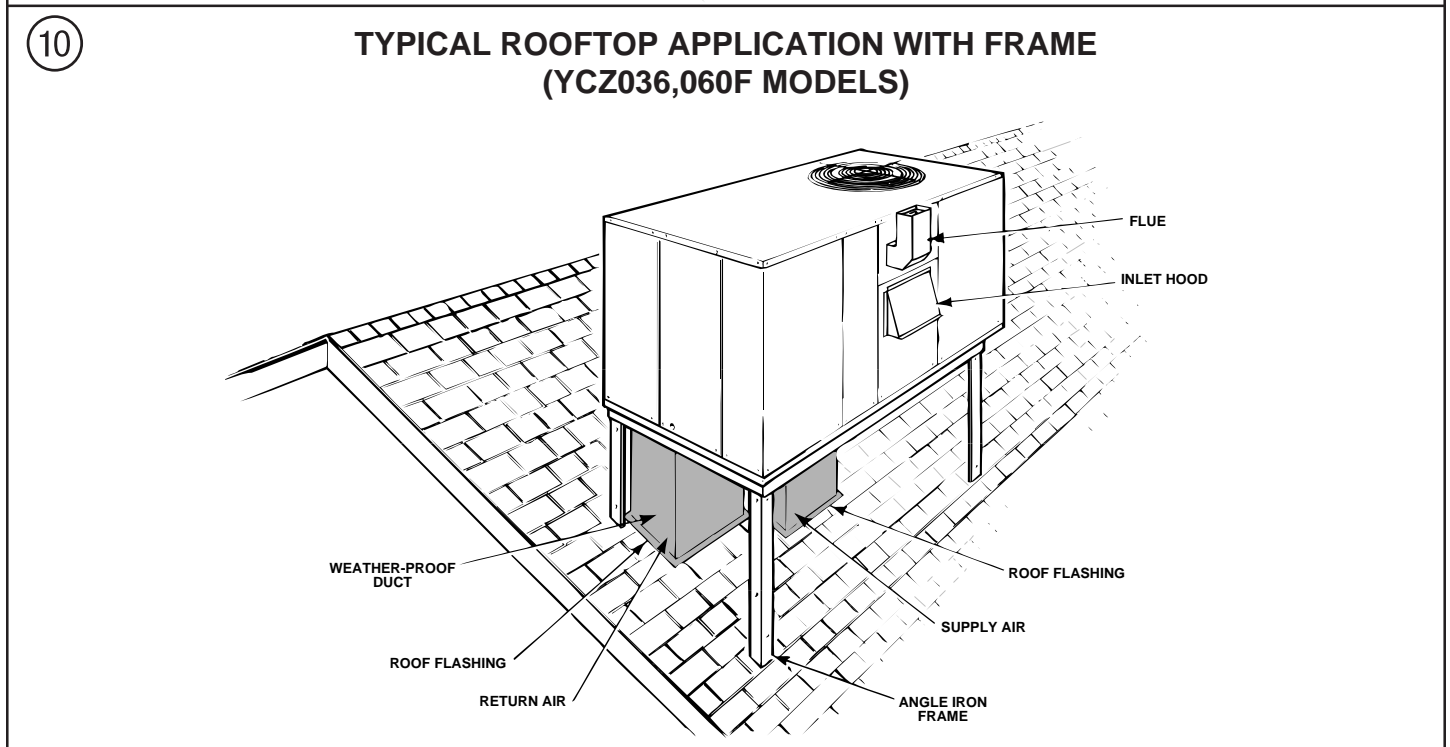
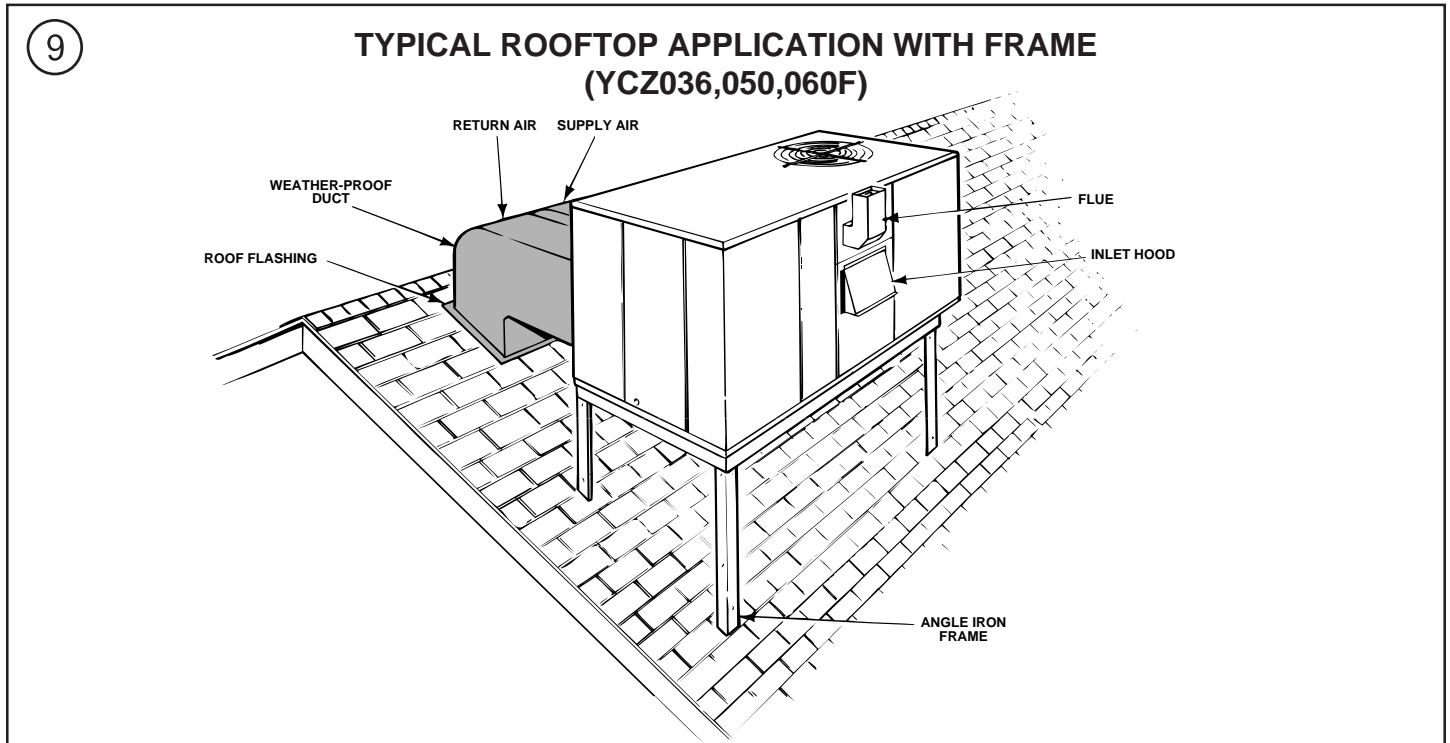

INSTALLATION

GROUND LEVEL -- HORIZONTAL UNITS

For ground level installations, the unit should be positioned on a pad the size of the unit or larger. The unit must be level on the pad. The pad must not come in contact with the structure (See Figure 11.) Be sure the outdoor portion of the supply and return air ducts are as short as possible.

Proceed with the installation as follows:

1. Place the unit on the pad and the five (5) rubber isolators provided.

2. Attach the supply and return air ducts to the unit.

3. Insulate any ductwork outside of the structure with at least 2 inches of insulation and weatherproof. There must be a weather-proof seal where the duct enters the structure.

4. Complete the installation according to the instructions in the following sections of this manual.

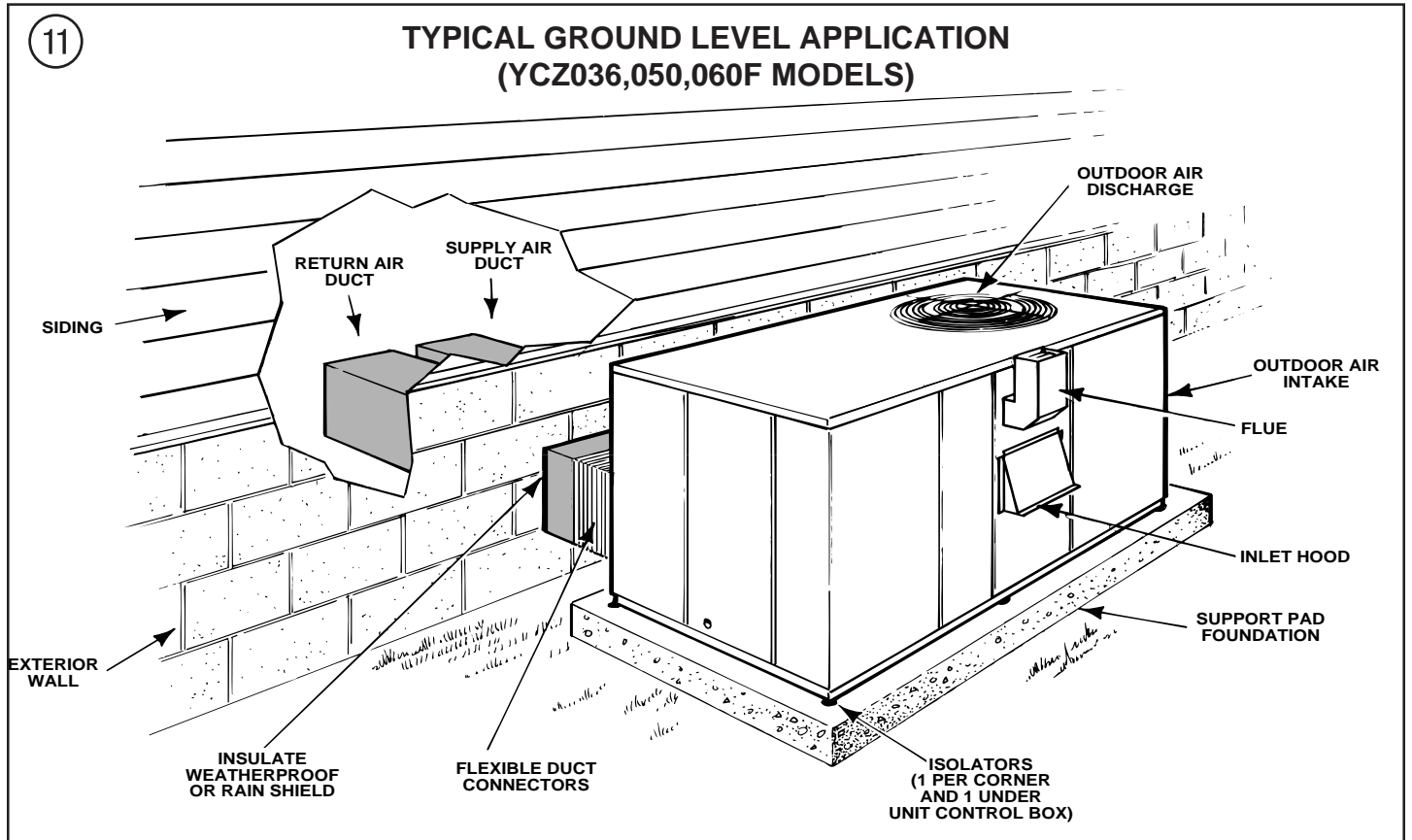

CONDENSATE DRAIN PIPING

A 3/4-inch female NPT condensate drain connection is provided on the evaporator access panel end of the unit. See Figure 4. Provide a trap and fill it with water before starting the unit to avoid air from being drawn through. Follow local codes and standard piping practices when running the drain line. Pitch the line downward away from the unit. Avoid long horizontal runs. See Figure 12.

NOTE: Do not use reducing fittings in the drain lines. The condensate drain must be:

- Made of 3/4" pipe size.
- Pitched 1/4" per foot to provide free drainage to convenient drain system.
- Trapped.
- Must not be connected to closed drain system.

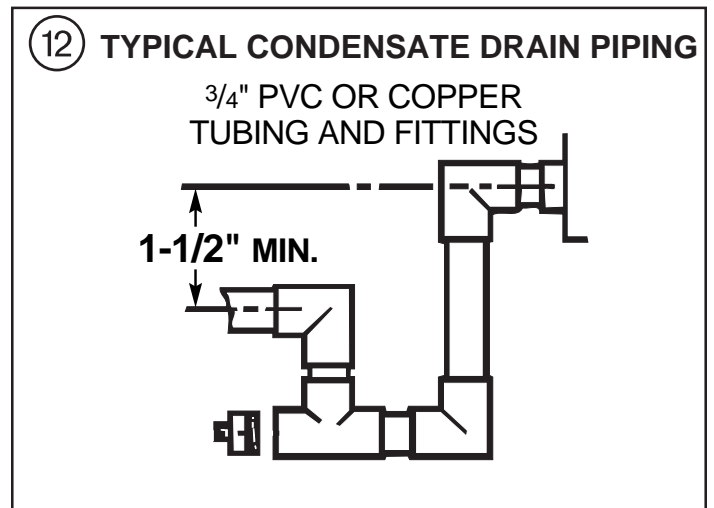

DUCTWORK

ATTACHING DOWNFLOW DUCTWORK TO ROOF CURB

Supply and return air flanges are provided on the roof curb for easy duct installation. All ductwork must be run and attached to the curb before the unit is set into place.

Follow these guidelines for ductwork construction:

Connections to the unit should be made with three-inch canvas connectors to minimize noise and vibration transmission.

Elbows with turning vanes or splitters are recommended to minimize air noise and resistance.

The first elbow in the ductwork leaving the unit should be no closer than two feet from the unit, to minimize noise and resistance.

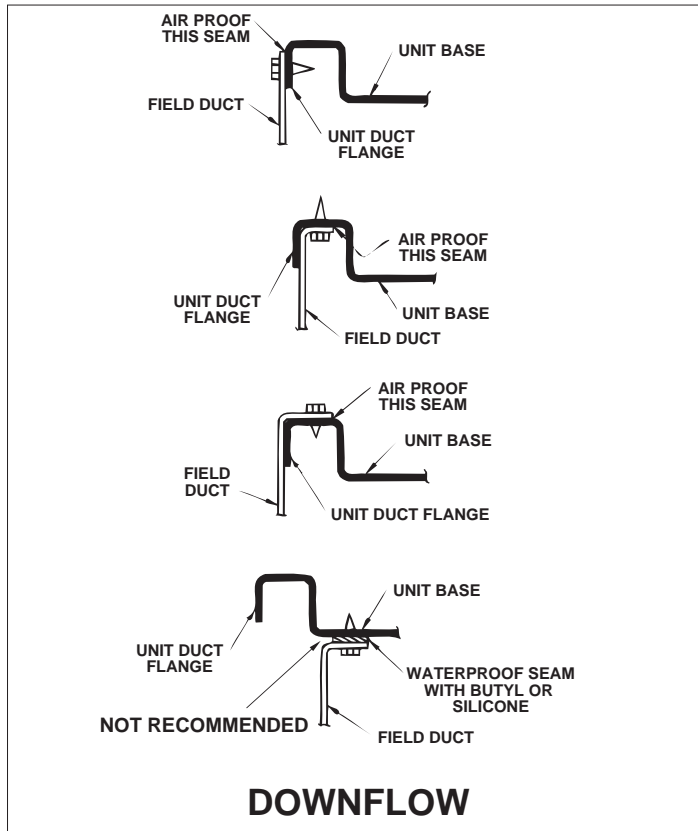

ATTACHING HORIZONTAL DUCTWORK TO UNIT

All conditioned air ductwork should be insulated to minimize heating and cooling duct losses. Use a minimum of two (2) inches of insulation with a vapor barrier. The outside ductwork must be weatherproofed between the unit and the building.

When attaching ductwork to a horizontal unit, provide a flexible watertight connection to prevent noise transmission from the unit to the ducts. The flexible connection **must** be indoors and made out of heavy canvas.

NOTE: Do not draw the canvas taut between the solid ducts.

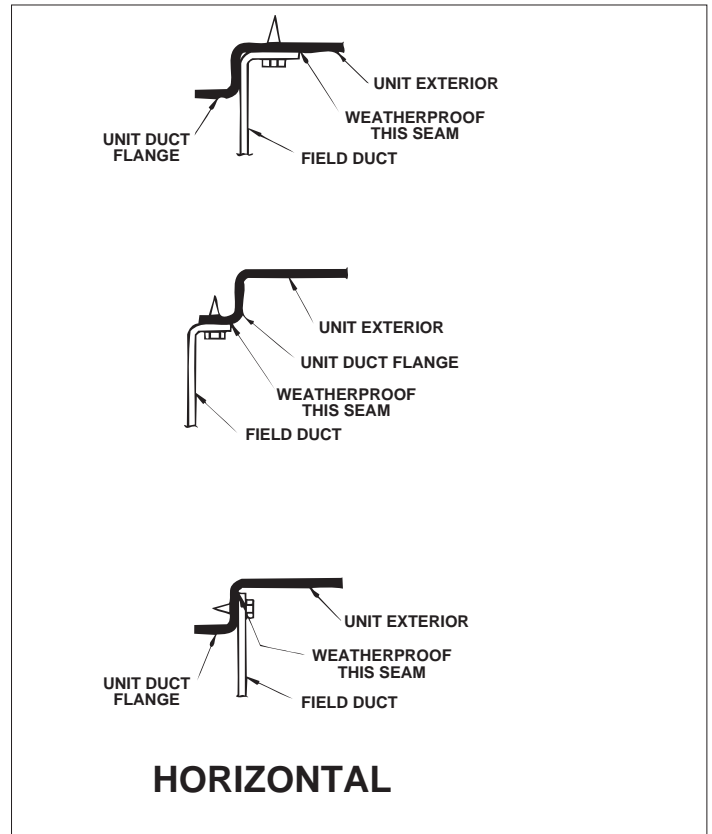

The following warning complies with State of California law, Proposition 65.

WARNING: This product contains fiberglass wool insulation! Fiberglass dust and ceramic fibers are believed by the State of California to cause cancer through inhalation. Glasswool fibers may also cause respiratory, skin, or eye irritation.

PRECAUTIONARY MEASURES

- Avoid breathing fiberglass dust.
- Use a NIOSH approved dust/mist respirator.
- Avoid contact with the skin or eyes. Wear long-sleeved, loose-fitting clothing, gloves, and eye protection.

- Wash clothes separately from other clothing: rinse washer thoroughly.
- Operations such as sawing, blowing, tear-out, and spraying may generate fiber concentrations requiring additional respiratory protection. Use the appropriate NIOSH approved respirator in these situations.

FIRST AID MEASURES

- Eye Contact** - Flush eyes with water to remove dust. If symptoms persist, seek medical attention.
- Skin Contact** - Wash affected areas gently with soap and warm water after handling.

GAS PIPING INSTALLATION

CAUTION: Before making the gas pipe connection give serious consideration to providing the required clearance necessary to remove the access panels on the unit (e.g., economizer and filter access panels).

NOTE: In the absence of local codes, the installation must conform with American National Standard--Z223.1--National Fuel Gas Code, Latest Revision.

The available gas supply must agree with the required gas supply marked on the unit nameplate. Minimum permissible gas supply pressure for purpose of **input adjustment** must be at least 7.0 in. w. c. (inches water column) for natural gas and 11 in. w. c. for LP gas.

PIPE DELIVERY SCHEDULE

NOTE: The following procedure and tables below apply to Natural Gas **only**.

1. Obtain from the gas company the heating value and specific gravity of the gas delivered.
2. Determine the exact length of pipe needed.
3. Read BTUH input nameplate on the furnace.
4. Use the multiplier opposite the specific gravity of the gas given in Table 1 below and insert in the following formula:

$$CFH = \frac{\text{Furnace Input in BTUH}}{\text{Gas Heat Content in BTU/Cu. Ft. X Multiplier}}$$

TABLE 1

This will give the factor for columns 2 through 6 in Table 2.

	SPECIFIC GRAVITY	MULTIPLIER
MULTIPLIERS TO BE USED WHEN THE SPECIFIC GRAVITY OF THE GAS IS OTHER THAN 0.60	.50	1.10
	.55	1.04
	.60	1.00
	.65	.962

5. Using Table 2, select the pipe length nearest to yours.

TABLE 2

6. Follow this line vertically down to the exact CFH found in Step 4 above or the next highest value.

NATURAL GAS ONLY

TABLE OF CUBIC FEET PER HOUR OF GAS FOR VARIOUS PIPE SIZES AND LENGTHS							
PIPE SIZE (inch)	LENGTH OF PIPE (feet)						
	10	20	30	40	50	60	70
1/2	132	92	73	63	56	50	46
3/4	278	190	152	130	115	105	96
1	520	350	285	245	215	195	180
1-1/4	1050	730	590	520	440	400	370

THIS TABLE IS BASED ON PRESSURE DROP OF 0.3 INCH W.C. AND 0.6 SP.GR. GAS

7. Read horizontally to the left of this column for the required pipe size diameter.

NOTE: If this is an LPG application, consult your LPG supplier for pipe sizes and deliveries.

GAS PRESSURE SETUP PRECAUTIONS

⚠ WARNING: NEVER USE AN OPEN FLAME TO TEST FOR GAS LEAKS: AN EXPLOSION COULD OCCUR, CAUSING INJURY OR DEATH.

IMPORTANT: The furnace and its individual shut-off valve must be disconnected from the gas supply piping system during any pressure testing of that system at test pressures exceeding 1/2 psig (3.48 kPa).

The furnace must be isolated from the gas supply piping system by closing its individual manual shut-off valve during any pressure testing of the gas supply piping system at test pressures less than or equal to 1/2 psig (3.48 kPa).

GAS SUPPLY LINE PRESSURE

Before connecting the unit to the gas supply line, be sure to determine the gas pressure in the line.

If the gas supply pressure is excessive (above 14 inches water column or 1/2 psig), install a pressure regulator either at the supply source or in the branch circuit serving the unit. Once the regulator is installed, set it to provide a pressure of 7 inches water column with the unit operating and no greater than 14 inches water column with the unit not firing.

NOTE: Gas pressure in excess of 14 inches water column (1/2 psig) may damage the regulator, while improper regulation may result at pressures lower than 5.5 inches water column at the unit inlet.

If the supply line pressure is below the minimum supply pressure indicated on the unit nameplate, contact the gas supply company.

Follow these steps to complete the installation of the unit gas piping. See Figure 14.

1. Install a tapped, Style A (1/8-inch NPT tap) shut-off gas cock at the end of the gas supply line near the unit. Be sure the tapped gas cock is downstream of the pressure regulator, if used.

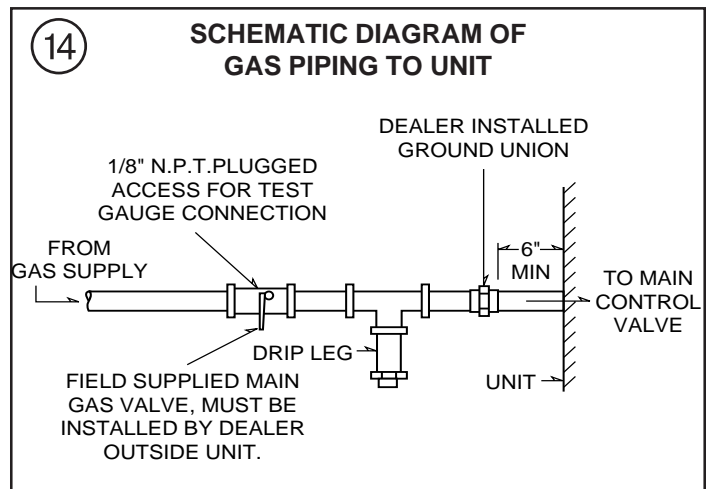

GAS PIPING INSTALLATION

NOTE: The shut-off gas cock must be installed outside of the unit and should meet the specifications of all applicable national and local codes.

2. Install a ground union joint downstream of the shut-off cock. This joint must also be installed outside of the unit.
3. Install a drip leg at least six (6) inches in depth next to the union as shown in Figure 14. This drip leg is required to collect any sediment that may be deposited in the line.
4. Before connecting the piping circuit to the unit, bleed the air from the supply line. Then cap or plug the line and test the pressure at the tapped shut-off cock. The pressure reading should not exceed 14 inches water column.
5. Using an appropriate backup wrench on the gas valve inlet boss, connect the gas piping to the unit. Check the completed piping for leaks using a soap and water solution or the equivalent.
6. After installation of the gas pipe in the unit, the pipe chase opening should be closed with the filler/barrier plug provided.

MANIFOLD PRESSURE

Check the manifold pressure at the unit gas valve. Do not exceed the recommended pressure shown on the unit nameplate.

15 BURNER & VALVE ILLUSTRATION

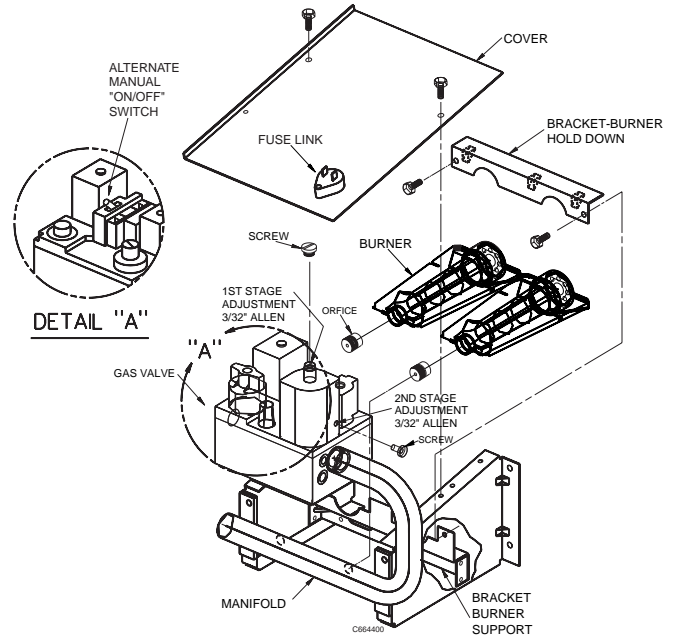

16

FLUE AND HOOD ILLUSTRATION

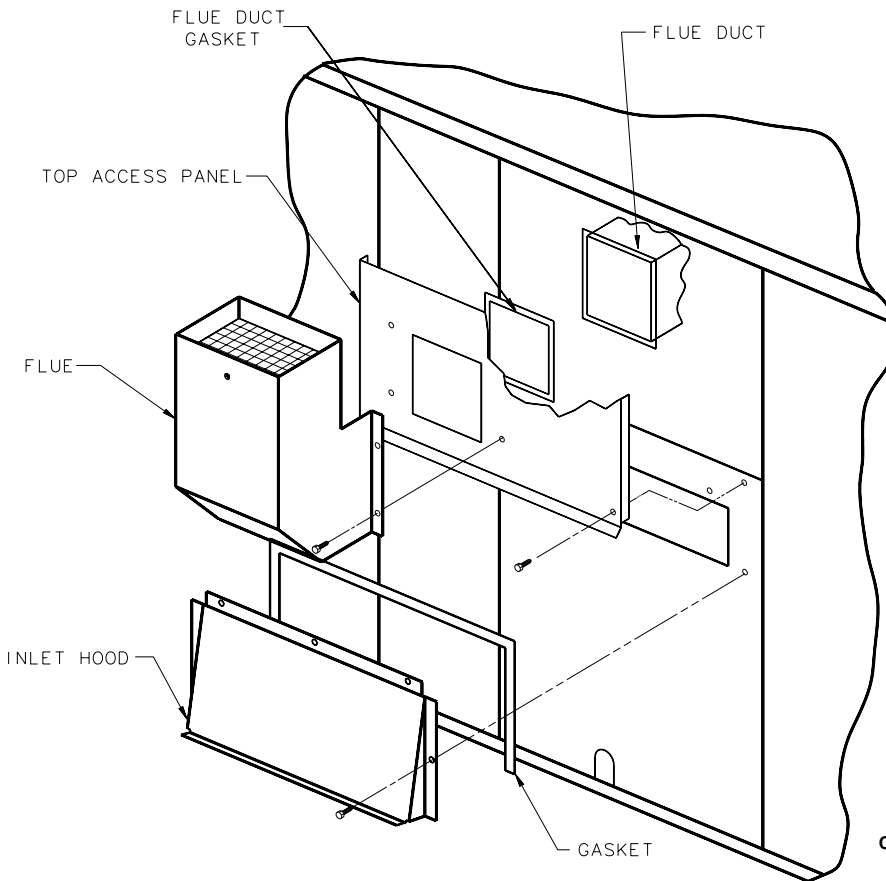

GAS PIPING INSTALLATION

INPUT CHECK AND ADJUSTMENT

1. Make sure all gas appliances are off except the furnace.
2. Clock the gas meter with the furnace operating (determine the dial rating of the meter) for one revolution.
3. Match the "Sec" column in the gas flow (in cfh) Table 3 with the time clocked.
4. Read the "Flow" column opposite the number of seconds clocked.
5. Use the following factors if necessary.
 - For 1 Cu. Ft. Dial Gas Flow CFH =
Chart Flow Reading / 2
 - For 1/2 Cu Ft. Dial Gas Flow CFH =
Chart Flow Reading / 4
 - For 5 Cu. Ft. Dial Gas Flow CFH =
10X Chart Flow Reading / 4
6. Multiply the final figure by the heating value of the gas obtained from the utility company and compare to the nameplate rating. This must not exceed the nameplate rating.
7. Changes can be made by adjusting the manifold pressure.

- a. Attach a manifold pressure gauge.
- b. Remove the slot screw on top of the gas valve for 1st stage manifold pressure adjustment. Remove slot screw on outlet side for 2nd stage adjustment (See Figure 17).
- c. Turn the adjustment nut in to increase the gas flow rate, and out to decrease the gas flow rate using a 3/32" hex wrench.

Note:

If Model YCZ036F1,3M is installed in a region where NOX must be below 40 nanograms per input to 72,000 BTUH.

HIGH ALTITUDE INSTALLATION

Unit nameplate ratings are based on equipment operation from sea level to 2000 feet elevation above sea level. If the unit installation is from 2000 - 4500 feet elevation, it will be necessary to change the burner orifices to the noted sizes, (ref. National Fuel Gas Code, sec 8.1.2, Appendix F, Table F4).

GAS TYPE	MAN. PRESS (in. W.C.)	ORIFICE SIZE 0 - 2000 ft	ORIFICE SIZE 2000 - 4500 ft
NATURAL	3.3	42*	43
PROPANE	10.0	54	55

* FACTORY SHIPPED

TABLE 3

GAS FLOW IN CUBIC FEET PER HOUR 2 CUBIC FOOT DIAL							
Sec.	Flow	Sec.	Flow	Sec.	Flow	Sec.	Flow
8	900	29	248	50	144	82	88
9	800	30	240	51	141	84	86
10	720	31	232	52	138	86	84
11	655	32	225	53	136	88	82
12	600	33	218	54	133	90	80
13	555	34	212	55	131	92	78
14	514	35	206	56	129	94	76
15	480	36	200	57	126	96	75
16	450	37	195	58	124	98	73
17	424	38	189	59	122	100	72
18	400	39	185	60	120	104	69
19	379	40	180	62	116	108	67
20	360	41	176	64	112	112	64
21	343	42	172	66	109	116	62
22	327	43	167	68	106	120	60
23	313	44	164	70	103	124	58
24	300	45	160	72	100	128	56
25	288	46	157	74	97	132	54
26	277	47	153	76	95	136	53
27	267	48	150	78	92	140	51
28	257	49	147	80	90	144	50

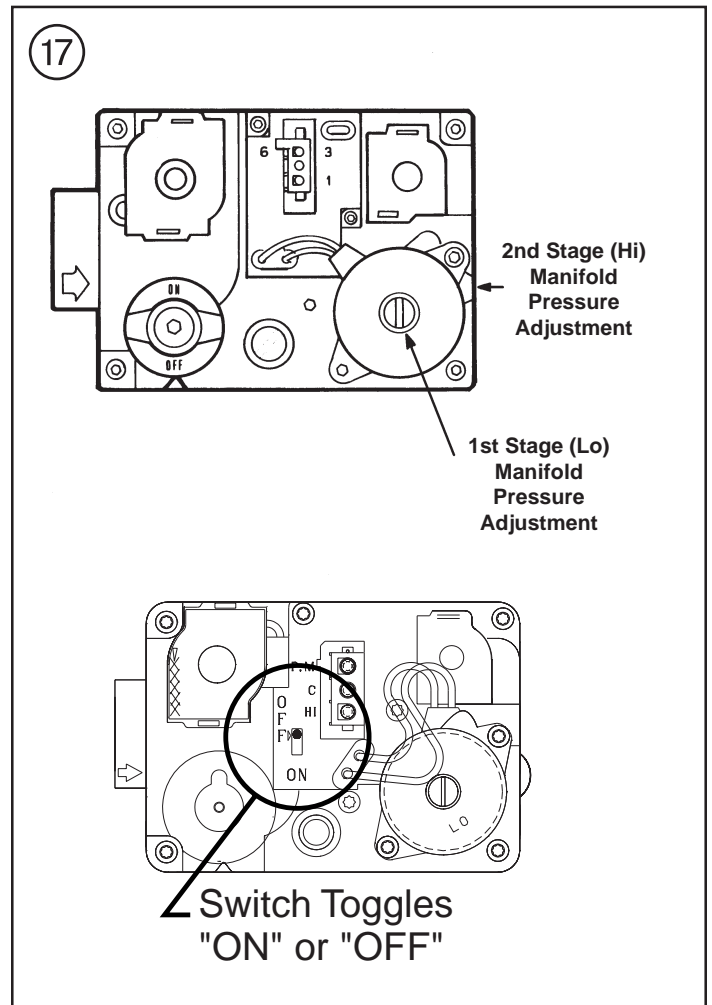

FILTER INSTALLATION

AIR FILTERS

Filters are to be used with the **YCZ036,050,060F** heating/cooling units. The basic unit does not have filters in it. However, a filter frame accessory is offered that will allow filters to be installed within the unit.

Otherwise a filter rack must be installed by the installer in the duct work.

Affix the filter label supplied with the unit adjacent to the filter area.

TABLE 4

UNIT	NOMINAL CFM	FILTER* Sq.Ft.- SIZE	FILTER RESISTANCE
YCZ036F	1200	4	0.05
YCZ050F	1600	5.33	0.05
YCZ060F	2000	6.67	0.05

*Filters must be installed in the return air system. The above square footages are based on 300 F.P.M. face velocity. If permanent filters are used, size per mfg. recommendation with clear resistance of 0.05" WC.

ELECTRICAL WIRING

ELECTRICAL CONNECTIONS

Electrical wiring and grounding must be installed in accordance with local codes or, in the absence of local codes, with the National Electrical Code ANSI/NFPA 70, Latest Revision.

ELECTRICAL POWER

It is important that proper electrical power be available for the unit. Voltage variation should remain within the limits stamped on the unit nameplate.

DISCONNECT SWITCH

Provide an approved weatherproof disconnect either on the side of the unit or within close proximity and **within sight of the unit**.

OVER CURRENT PROTECTION

The branch circuit feeding the unit must be protected as shown on the unit rating plate.

POWER WIRING

The power supply lines must be run in weathertight conduit to the disconnect and into the bottom of the unit control box. Provide strain relief for all conduit with suitable connectors.

Provide flexible conduit supports whenever vibration transmission may cause a noise problem within the building structure.

Be sure all connections are made tight. See Figure 18.

NOTE: Unit must be grounded for ignitor to operate properly. Gas pipe to unit is not an adequate ground. Ground the unit internally as provided. See wiring diagram for location.

CONTROL WIRING (CLASS II)

Low voltage control wiring should not be run in conduit with power wiring unless Class 1 wire of proper voltage rating is used. Route the thermostat cable or equivalent single leads of No. 18 AWG colored wire from the thermostat subbase terminals through the rubber grommet on the unit. See Figures 3 and 4 for the control entry location. Make connections as shown on the unit wiring diagram and in Figure 18.

Do not short thermostat wires since this will damage the control transformer.

Recommended wire sizes and lengths for installing the unit thermostat are provided in Table 5. The total resistance of these low voltage wires must not exceed one (1) ohm. Any resistance in excess of 1 ohm may cause the control to malfunction because of the excessive voltage drop.

**TABLE 5
THERMOSTAT WIRE SIZE AND MAXIMUM LENGTH**

WIRE SIZE	MAXIMUM LENGTH (Ft)
18	75
16	125
14	200

THERMOSTAT HEAT ANTICIPATOR

The thermostat heat anticipators should be set to .4 amps on single or two stage thermostats.

IMPORTANT: Upon completion of wiring check all electrical connections, including factory wiring within the unit, make sure all connections are tight. Replace and secure all electrical box covers and access doors before leaving the unit or turning on the power to the unit.

NOTES: For branch circuit wiring (main power supply to unit disconnect), wire size for the length of run should be determined using the circuit ampacity found on the unit nameplate and the N.E.C.

For more than 3 conductors in a raceway or cable, see the N.E.C. for derating the ampacity of each conductor.

GROUNDING: THE UNIT MUST BE ELECTRICALLY GROUNDED IN ACCORDANCE WITH LOCAL CODES OR THE NATIONAL ELECTRIC CODE.

ELECTRICAL WIRING

After all electrical wiring is complete, **set the thermostat system switch in the OFF position so that the compressor will not run** and then apply power by closing the system main disconnect switch. This will activate the compressor sump heat. Do not change

the Thermostat System Switch until power has been applied long enough to evaporate any liquid R-22 in the compressor. It is recommended that the sump heater be energized for eight (8) hours prior to starting.

18

YCZ-F FIELD WIRING DIAGRAM PACKAGED GAS-ELECTRIC UNIT

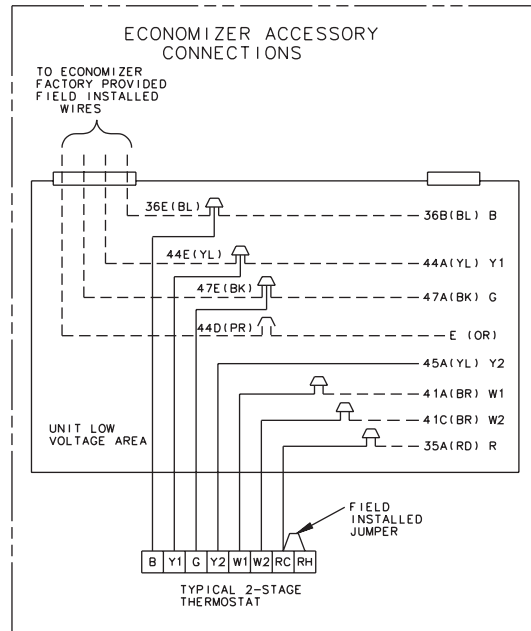
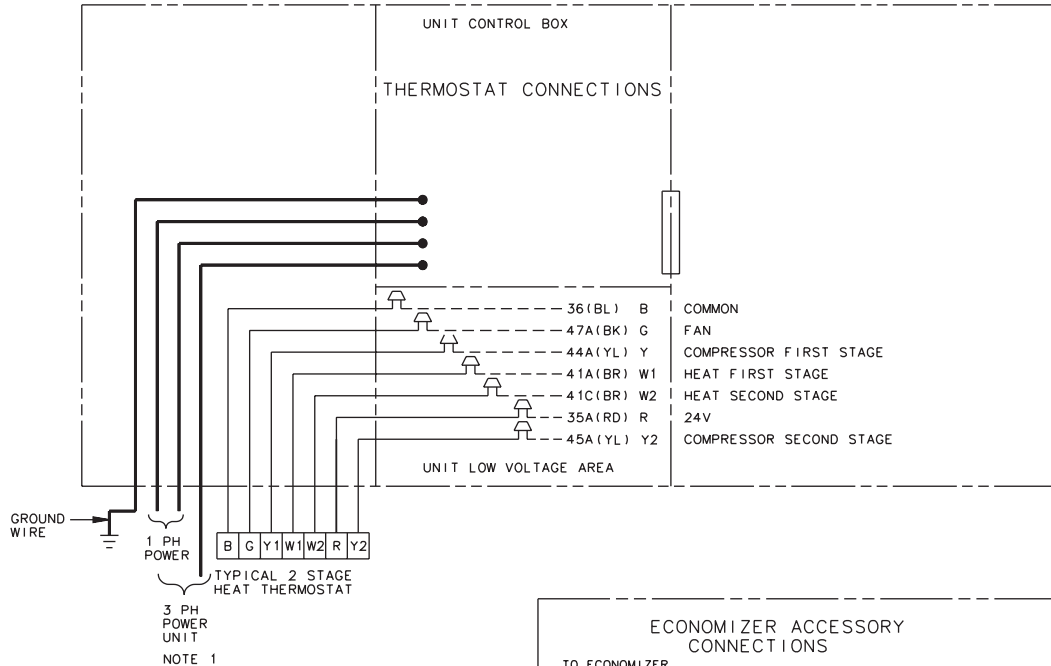

NOTES:

1. FUSED DISCONNECT SIZE, POWER WIRING AND GROUNDING OF EQUIPMENT MUST COMPLY WITH CODES.
2. BE SURE POWER SUPPLY AGREES WITH EQUIPMENT AND HEATER NAMEPLATE.
3. LOW VOLTAGE WIRING TO BE 18 AWG MINIMUM CONDUCTOR.
4. SEE UNIT DIAGRAM FOR ELECTRICAL CONNECTION DETAILS.
5. THE THERMOSTAT ON THE GAS/ELECTRIC UNIT MUST PROVIDE A 'G' SIGNAL IN THE COOLING MODE ONLY. DURING THE HEATING MODE THE FAN WILL BE ENERGIZED BY THE SYSTEM.
6. FOR SINGLE STAGE THERMOSTATS JUMPER W1 AND W2 TOGETHER. SECOND STAGE HEAT WILL BEGIN 10 MINUTES AFTER FIRST STAGE.

INTER-COMPONENT WIRING

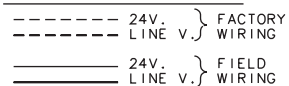

WIRE COLOR DESIGNATION			
ABBR	COLOR	ABBR	COLOR
BK	BLACK	PR	PURPLE
BL	BLUE	RD	RED
BR	BROWN	WH	WHITE
GR	GREEN	YL	YELLOW
OR	ORANGE		

START - UP

PRE-START QUICK CHECKLIST

- Is the unit properly located and level with the proper clearance? See Figure 4.
- Is the duct work correctly sized, run, taped, insulated, and weatherproofed with proper unit arrangement? See Ductwork Installation section.
- Is the gas piping correctly sized, run, trapped, and purged of air? See Gas Piping section.
- Is the condensate line properly sized, run, trapped, and pitched?
- Is the filter of the correct size and number? Is it clean and in place?
- Is the wiring properly sized and run according to the unit wiring diagram?
- Are all the wiring connections, including those in the unit, tight?
- Has the unit been properly grounded and fused with the recommended fuse size? See Wiring Data.
- Is the thermostat level, correctly wired, well located, and set for the proper heat anticipation?
- Have the air conditioning systems been checked at the service ports for charge and leak tested if necessary?
- Does the condenser fan and indoor blower turn free without rubbing, and are they tight on the shafts?
- Has the indoor blower speed been determined and the proper speed been set? See the Unit Wiring Diagram.
- Has all work been done in accordance with applicable local and national codes?
- Are all covers and access panels in place to prevent air loss and safety hazards?

STARTING THE UNIT IN THE COOLING MODE

CAUTION: Before starting the system on the cooling cycle, turn the thermostat switch to OFF and close the unit disconnect switch. This procedure energizes the compressor crankcase heater, vaporizing any liquid refrigerant in the crankcase. This is a precaution against foaming at start-up which could damage the compressor bearings. **Allow the heater to operate a minimum of eight (8) hours.**

NOTE: See the section on “Sequence of Operation” for a description of the cooling operating sequence.

To start the unit in the cooling mode, set the thermostat system switch to COOL and move the thermostat COOL indicator to a setting below room temperature. The condenser (outdoor) fan motor compressor and evaporator (indoor) fan motor will operate automatically.

OPERATING PRESSURES

After the unit has operated in the cooling mode for a short period of time, install pressure gauges on the gauge ports of the discharge and suction line valves. Check the suction and discharge pressures and compare them to the normal operating pressures provided in the unit's *SERVICE FACTS*.

NOTE: Do not use the pressures from the unit's *SERVICE FACTS* to determine the unit refrigerant charge. The correct charge is shown on the unit nameplate. To charge the system accurately, weigh in the charge according to the unit nameplate.

VOLTAGE

With the compressor operating, check the line voltage at the unit. The voltage should be within the range shown on the unit nameplate. If low voltage is encountered, check the size and length of the supply line from the main disconnect to the unit. The line may be undersized for the length of the run.

COOLING SHUT DOWN

Place the system selector in the OFF position or reset thermostat at a setting above room temperature.

Do not de-energize the main power disconnect except when unit is to be serviced. Power is required to keep the heat pump compressor warm and boil off refrigerant in the compressor.

HEATING CYCLE

NOTE: See Sequence of Heating Operation.

These units are equipped with a solid-state ignition control that lights the burners each time the thermostat calls for heat. The burners are extinguished during the OFF cycle.

The gas heating section of the unit can be started using the following procedure:

1. Be sure the thermostat is at its lowest setting and the power to the unit is off.
 - a. Turn the main shutoff valve on the gas supply line ON.
 - b. Turn or switch the manual valve on the combination gas valve ON position.
2. Be sure the burner compartment access panel is in place.
 - a. Turn on the electrical power to the unit.
 - b. Turn the thermostat to the highest setting in the heating cycle.
3. As the thermostat calls for heat, the system cycles as follows:
 - a. The combustion blower is energized.
 - b. The pressure switch is closed.
 - c. The gas valve opens and the ignitor lights the burner.
 - d. Cycle the thermostat on and off a few times to check out the control system and burner operation characteristics.
4. With the burners operating, check the manifold pressure with a manometer. Do not exceed recommended pressures.
5. Adjust the unit to obtain an air temperature rise with that specified on the unit nameplate.
6. **NOTE:** For manifold pressures and orifice sizes for gas with other BTU ratings, contact the local gas utility. Manifold pressure should be 3.3 inches water column (+0.1). Input must **not** exceed the value shown on the rating plate.
7. Set the heat anticipator of the thermostat to equal the amperage draw of the gas valve, approximately 0.7.

START - UP

8. Set the thermostat at the desired temperature setting and the unit will function automatically.

STARTING THE UNIT IN THE GAS HEATING MODE

1. Check to make sure all grilles and registers are open and all unit access doors are closed before start-up.
2. Purge the gas supply line of air by opening the union ahead of the unit. When the odor of gas is detected, retighten the union and wait five (5) minutes before proceeding.
3. Set the wall thermostat to its lowest position and place the fan switch in the AUTO or ON position.
4. Open the main gas valve(s) and turn on the unit power supply.
5. Reset the heating temperature lever on the room thermostat at the highest value above room temperature. The combustion blower motor should energize. The main burners should light within 20-25 seconds. Initial start may be delayed somewhat if the unit has not been purged and air is trapped in the gas line.

NOTE: Blue smoke produced by the heat exchanger during the initial burner firing is caused by a thin film of oil on the surface of the heat exchanger. This oil will burn off quickly.

6. Cycle the thermostat OFF and ON a few times at a rate of not more than once every thirty (30) seconds. Check both the control operation and the burner operating conditions.

MANIFOLD PRESSURE

1. Connect a manometer to the pressure tap at the outlet side of the unit's gas valve. Read the manifold pressure with the main burners firing.
2. If the manifold pressure reading does not match the value indicated on the unit nameplate, the unit pressure regulator must be adjusted as follows:
 - a. Remove the cover screw on the gas regulator located on the front side of the unit's gas valve.
 - b. Turn the adjusting screw clockwise to increase manifold pressure or counterclockwise to decrease manifold pressure.
3. Check the temperature rise during furnace operation to insure that it falls within the range specified on the unit nameplate.
4. If the temperature rise noted is outside of the specified limits, adjust the indoor air flow to cause the temperature rise of the heat exchanger to fall within the required range.

SEQUENCE OF OPERATION

Operation of the unit heating or cooling cycles is controlled by the setting of the system switch on the room thermostat. Once the system switch is placed either in the "HEAT" or "COOL" position, unit operation is automatic. A fan switch on the thermostat also provides for its continuous operation of the evaporator fan when desired. The fan switch "ON" position provides continuous operation while the "AUTO" position provides operation during the heating or cooling cycles.

HEATING CYCLE

Thermostat call for heat (2-stage thermostat)

Call for 1st stage only:

(R) and (W1) thermostat contacts close signaling the control module (IGN) to run its self-check routine. After the control has verified that the pressure switch (PS) contacts are open, the limit switch (TCO) contacts are closed, and the flame rollout (FL) switch is closed, the induced draft blower (CBM) will be energized on high speed for approximately 15 seconds.

After the induced draft blower (CBM) has come up to speed, the control will verify that the pressure switch (PS) contacts are closed and switch the induced draft blower to low speed for an additional 5 seconds of prepurge. The gas valve (GV) is energized in the first stage to permit gas flow and the spark ignitor (IP) is energized. The flame detector (FD) confirms that ignition has been achieved within the 7 second trial period.

As the flame detector confirms that ignition has been achieved the delay to indoor fan on period begins timing and after approximately 45 seconds, the indoor blower motor (IDM) will be energized at low speed and will continue to run during the heating cycle.

Call for 2nd stage after 1st stage:

(R) and (W2) thermostat contacts close signaling a call for second stage heat. The induced draft motor (CBM) is energized on high speed and the gas valve on second stage. After approximately 30 seconds the control energizes the indoor blower on high speed.

2nd stage satisfied, 1st stage still called:

(R) and (W2) opens, the induced draft blower is reduced to low speed the gas valve is reduced to first stage. After approx. 30 seconds the indoor blower motor is reduced to low speed.

1st stage satisfied:

(R) and (W1) opens, the gas valve (GV) will close. The induced draft blower (CBM) will be de-energized after approximately 5 seconds postpurge. The indoor blower motor (IDM) will continue to run for the fan off period (field selectable 60 or 90 seconds [by jumpers]), then will be de-energized by the control module.

Thermostat satisfied:

(R) and (W1/W2) (jumpered) contacts open signaling the control module to close the gas valve and de-energize the induced draft blower after approximately 5 second postpurge. The I.D. blower motor will continue to operate at the current speed for 60 or 90 seconds after the flames are extinguished .

SAFETY SEQUENCES

This product is equipped with safety devices to protect against abnormal conditions.

The temperature limit switch (TCO) is located in the gas compartment on the vestibule panel above the burner assembly. This automatic reset device protects against excessive leaving air temperature. If this device opens, the gas valve is immediately closed and will not permit operation until the limit switch closes.

SEQUENCE OF OPERATION

The rollout switch (FS) is located in the gas compartment near the inlet of the burners. This is a single use device designed to protect against any form of flame rollout. If this device is opened the gas valve is immediately de-energized and the control (IGN) will lockout the system. The rollout switch (FS) must be replaced before operation is allowed to continue.

The pressure switch (PS) is located in the upper right side of the gas compartment. This automatic device assures adequate combustion air pressure. If pressure against the induced draft blower outlet becomes excessive, the pressure switch will react and shut off the gas valve, until acceptable combustion pressure is again available.

If the control (IGN) does not sense flame within the first trial for ignition period. The gas valve will be de-energized. The control (IGN) will initiate a 60 seconds interpurge. Following the interpurge, on the second trial the gas valve will be energized on second stage (high heat input). If the flame is sensed within 10 seconds after the second try and only a call for first stage exists, the gas valve will be reduced to first stage. If the second try is not successful. The control will start other 60 second interpurge. After the interpurge, a third attempt will be tried. The gas valve will be energized on second stage (high heat input). If the flame is sensed within 10 seconds after the third try and only a call for first stage exists, the gas valve will be reduced to first stage. If the third try is not successful. The control will lock out.

If loss of flame occurs during a heating cycle, the control (IGN) will close the gas valve. The control will than recycle the ignition sequence, then if ignition is not achieved, it will shut off the gas valve and lock out the system.

If control lock out occurs, the control (IGN) will retry a complete ignition sequence in 1 hour.

The control (IGN) can be reset by removing power to the unit or by turning the thermostat from "on" to "off" for approximately three seconds, then back "on."

COOLING CYCLE

Thermostat call for cool (2-stage thermostat)

Call for 1st stage only:

With the room thermostat system switch in the "COOLING" position and the fan switch in the "AUTO" position, the Y1 thermostat contacts closes to the micro board, (the board will wait 3 seconds to check if the Y2 may also be calling) the micro will energize (CC1) and the outdoor fan relay for low speed and the G thermostat contact to G-IGN and to G1 on the ICMC is energized. (The status light is flashing and the Y1 light is on.)

The energized compressor contactor (CC1) completes the circuit to the compressor (CPR1), If the compressor safety controls are closed, the compressor (CPR1) will operate with the outdoor fan motor (ODM) on low speed. The indoor fan motor (IDM) will operate on low speed. The thermostat will continue to cycle the compressor and fans to maintain the desired temperature.

With the thermostat fan switch in the "ON" position, the G thermostat contact is closed to G1 on the ICMC board and the indoor fan motor (IDM) will continue to run on low speed regardless of compressor and condenser fan operation.

Call for 2nd stage after 1st stage:

The Y2 thermostat contact closes to the control board. For 1 minute both compressors are off, (all lights are flashing for 1 minute), than the board will energize the (CC2) compressor contactor, and the outdoor fan relay for high speed then the board (YCZ050 ONLY- will energize the (CC1) and 1 second later the (CC2) compressor contactors) and the indoor fan high to the Y on the ICMC board is energized for indoor high speed fan operation. (The status light is flashing and the Y1 and Y2 lights are on.)

2nd stage satisfied, 1st stage still called:(YCZ036,060F ONLY)

The Y2 thermostat contact opens to the control board. For 1 minute both compressors are off, (the status and Y1 light are flashing for 1 minute), than the board will energize (CC1) low compressor contactor, and the outdoor fan relay for low speed and indoor fan for low speed. (The status light is flashing and the Y1 light is on.)

2nd stage satisfied, 1st stage still called:(YCZ050 ONLY)

The Y2 thermostat contact opens to the control board. The board will de-energize (CC2) second compressor contactor, and energize the outdoor fan relay for low speed and indoor fan for low speed. (The status light is flashing and the Y1 light is on.)

ICM FAN MOTOR ADJUSTMENTS

If the airflow needs to be increased or decreased, see the Indoor Blower Performance Table below. Information on changing the dip switch settings for speed control of the blower motor is in this table. Blower speed changes are made on the ICM Fan Control mounted in the control box. The ICM Fan Control controls the variable speed motor.

There is a bank of 8 dip switches, (See Figure below), located at the lower right side of the board. The dip switches work in pairs to select the cooling/heat airflow (CFM/TON), and Fan off-delay options.

INDOOR BLOWER TIMING

The ICM Fan Control controls the variable speed indoor blower. The FAN-OFF period is set on the ICM Fan Control board by dip switches #5 and #6.

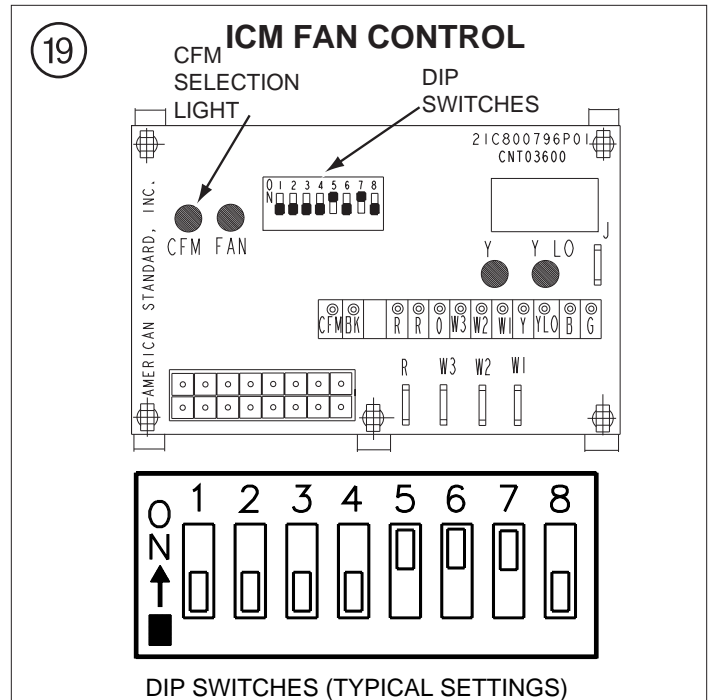

MAINTENANCE

ROUTINE MAINTENANCE BY OWNER

You can do some of the periodic maintenance functions for your **YCZ-F** unit yourself; this includes replacing the disposable or cleaning the permanent air filters, cleaning the unit cabinet, cleaning the condenser coil, and conducting a general unit inspection on a regular basis.

When the system is in constant operation. In new homes, check the filters every week for the first four (4) weeks.

If you have disposable-type filters, replace them with new filters of the same type and size. **Do not attempt to clean disposable filters.**

Permanent-type filters can be cleaned by washing them with a mild detergent and water. Make sure that the filters are thoroughly dry before reinstalling them in the unit (or duct system).

NOTE: It may be necessary to replace permanent filters annually if washing fails to clean the filter or if the filter shows signs of deterioration. Be sure to use the same type and size as was originally installed.

CONDENSER COIL

Unfiltered air circulates through the unit's condenser coil and can cause the coil's surface to become clogged with dust, dirt, etc. To clean the coil, vertically (i.e., with the fins) stroke the coil surface with a soft-bristled brush.

Be sure to keep all vegetation away from the condenser coil area.

⚠ WARNING: TO PREVENT AN EXPLOSION OR POSSIBLE INJURY, DEATH AND EQUIPMENT DAMAGE, DO NOT STORE COMBUSTIBLE MATERIALS, GASOLINE

MAINTENANCE PERFORMED BY SERVICEMAN--COOLING SEASON

To keep your unit operating safely and efficiently, the manufacturer recommends that a qualified serviceman check the entire system at least once each year and any other time that you feel one is needed. Your serviceman should examine these areas of your DCX-F unit:

- filters (for cleaning or replacement)
- motors and drive system components
- economizer gaskets (for possible replacement)
- safety controls (for mechanical cleaning)
- electrical components and wiring (for possible replacement and connection tightness)
- condensate drain (for cleaning)
- unit duct connections (to see that they are physically sound and sealed to the unit casing)
- unit mounting support (for structural integrity)
- the unit (for obvious unit deterioration)

MAINTENANCE PERFORMED BY SERVICEMAN--HEATING SEASON

Complete the unit inspections and service routines described below at the beginning of each heating season.

- Visually inspect the unit to ensure that the airflow required for combustion and condenser coil is not obstructed from the unit.
- Inspect the control panel wiring to verify that all electrical connections are tight and that the wire insulation is intact.
- Check the operation of the gas ignition system as follows: Turn off the gas supply with the unit operating to verify that the gas valve closes and that a ignition cycle is initiated by the unit.
- Visually inspect the inside of the burners and the burner ports for deposit buildup and corrosion. Wipe and brush the inside of the burner and the burner ports and then clean with a dry cloth. If the deposit buildup or corrosion is excessive, replace the burners.

FLUE CLEANING

Before each heating season, the flue should be inspected for signs of flaking rust and soot deposits. **Dirty flues should be cleaned by qualified service personnel ONLY** using the following procedure:

1. Turn the room thermostat to the OFF position. Turn the main power disconnect OFF. Turn the manual gas valve OFF.
2. Remove the flue cap, the lower access panel, and the upper access panel.
3. Remove the combustion blower assembly from the fluebox. Remove the flue box and the flue restrictors.
4. Remove all wires from the gas valve while carefully noting their location.
5. Disconnect the gas supply line from the valve.
6. Remove the manifold retaining screws and pull the burner-manifold assembly from the heat exchanger.
7. Remove the inlet turbulators being careful not to break or damage them.
8. Wipe the flue box and flue baffles clean with a clean, dry cloth.
9. **CAUTION: Never use combustible cleaning fluids on any part of the furnace.**
10. Replace all gaskets with new ones.
11. Replace all damaged or broken turbulators with new ones.
12. Reassemble the unit by reversing Steps 2 through 7 above. Take care that all gaskets seat properly.
13. Check all wires for correct installation by referring to the unit's electrical wiring diagram.
14. Leak test all gas line connections with a soap and water solution or the equivalent.
15. Reinstall the top and bottom access panels and the flue stack.
16. Visually inspect the unit to ensure that the airflow opening for combustion is not obstructed.
17. Follow the start-up procedure above to place the unit back in service.

⚠ WARNING: DO NOT OPERATE THE UNIT WITHOUT THE EVAPORATOR FAN ACCESS PANEL IN PLACE. REINSTALL THE ACCESS PANEL AFTER PERFORMING ANY MAINTENANCE PROCEDURES ON THE FAN. OPERATING THE UNIT WITHOUT THE ACCESS PANEL PROPERLY INSTALLED MAY RESULT IN SEVERE PERSONAL INJURY OR DEATH.

LIMITED WARRANTY

COMBINATION GAS ELECTRIC AIR CONDITIONER YCZ, YCY AND YCX

Models Less Than 20 Tons for Residential Use*
(Parts Only)

This limited warranty is extended by American Standard Inc., to the original purchaser and to any succeeding owner of the real property to which the Combination Gas Electric Air Conditioner is originally affixed, and applies to products purchased and retained for use within the U.S.A. and Canada.

If any part of your Combination Gas Electric Air Conditioner fails because of a manufacturing defect within five years from the date of the original purchase, Warrantor will furnish without charge the required replacement part. Any local transportation, related service labor, diagnosis calls, air filters, refrigerant and related items are not included.

In addition, if the sealed motor-compressor(s) fail(s) or the outdoor coil[†] should become defective, either or both events occurring because of a manufacturing defect within the sixth through tenth year from the date of original purchase, Warrantor will furnish without charge the required replacement compressor and/or outdoor coil. Any local transportation, related service labor, diagnosis calls, refrigerant and related items are not included.

[†]NOTE: If your Combination Gas Electric Air Conditioner is installed within one mile of salt water, including but not limited to seacoasts and inland waterways, your outdoor coil warranty as stated above is limited to five years from the date of original purchase.

In addition, if the steel heat exchanger fails because of a manufacturing defect within the sixth through twentieth year from the date of original purchase, Warrantor will furnish without charge a replacement heat exchanger. Any local transportation, related service labor and diagnosis calls are not included.

This limited warranty does not cover failure of your combination gas electric air conditioner if it is damaged while in your possession, damage caused by unreasonable use of the combination gas electric air conditioner and/or damage from **failure to properly maintain** the combination gas electric air conditioner as set forth in the Use and Care manual (**see Proper Maintenance section**).

This limited warranty applies to product installed on or after 10/1/2001 where product is manufactured after 1/1/2000. This limited warranty is not retroactive to any installations prior to 10/1/2001 or on product produced prior to 2000.

THE LIMITED WARRANTY AND LIABILITY SET FORTH HEREIN ARE IN LIEU OF ALL OTHER WARRANTIES AND LIABILITIES, WHETHER IN CONTRACT OR IN NEGLIGENCE, EXPRESS OR IMPLIED, IN LAW OR IN FACT, INCLUDING IMPLIED WARRANTIES OF MERCHANTABILITY AND FITNESS FOR PARTICULAR USE, AND IN NO EVENT SHALL WARRANTOR BE LIABLE FOR ANY INCIDENTAL OR CONSEQUENTIAL DAMAGES.

Some states do not allow limitations on how long an implied limited warranty lasts or do not allow the exclusion or limitation of incidental or consequential damages, so the above limitation or exclusion may not apply to you. This limited warranty gives you specific legal rights, and you may also have other rights which vary from state to state.

Parts will be provided by our factory organization through an authorized service organization in your area listed in the yellow pages. If you wish further help or information concerning this limited warranty, contact:

American Standard Inc.
Troup Highway
Tyler, TX 75711-9010
Attention: Manager, After Sales Support

GW-631-1802

*This limited warranty is for residential usage of this equipment and not applicable when this equipment is used for a commercial application. A commercial use is any application where the end purchaser uses the product for other than personal, family or household purposes.

LIMITED WARRANTY
COMBINATION GAS ELECTRIC AIR CONDITIONER
YCZ, YCY, YCX, YCC, YCD, YCH, YCP, YHC and YSC
Models Less Than 20 Tons for Commercial Use*
(Parts Only)

This warranty is extended by American Standard Inc., to the original purchaser and to any succeeding owner of the real property to which the Combination Gas Electric Air Conditioner is originally affixed, and applies to products purchased and retained for use within the U.S.A. and Canada. There is no warranty against corrosion, erosion or deterioration.

If any part of your Combination Gas Electric Air Conditioner fails because of a manufacturing defect within one year from the date of the original purchase, Warrantor will furnish without charge the required replacement part.

In addition, if the sealed motor-compressor fails because of a manufacturing defect within the second through fifth year from the date of original purchase, Warrantor will furnish without charge the required replacement compressor.

In addition, if the steel heat exchanger fails because of a manufacturing defect within the second through fifth year from the date of original purchase, Warrantor will furnish without charge a replacement heat exchanger.

Warrantor's obligations and liabilities under this warranty are limited to furnishing F.O.B. Warrantor factory or warehouse at Warrantor designated shipping point, freight allowed to Buyer's city, replacement parts for Warrantor's products covered under this warranty. Warrantor shall not be obligated to pay for the cost of lost refrigerant. No liability shall attach to Warrantor until products have been paid for and then liability shall be limited solely to the purchase price of the equipment under warranty shown to be defective.

THE WARRANTY AND LIABILITY SET FORTH HEREIN ARE IN LIEU OF ALL OTHER WARRANTIES AND LIABILITIES, WHETHER IN CONTRACT OR IN NEGLIGENCE, EXPRESS OR IMPLIED, IN LAW OR IN FACT, INCLUDING IMPLIED WARRANTIES OF MERCHANTABILITY AND FITNESS FOR PARTICULAR USE, AND IN NO EVENT SHALL WARRANTOR BE LIABLE FOR ANY INCIDENTAL OR CONSEQUENTIAL DAMAGES.

Some states do not allow limitations on how long an implied warranty lasts or do not allow the exclusion or limitation of incidental or consequential damages, so the above limitation or exclusion may not apply to you. This warranty gives you specific legal rights, and you may also have other rights which vary from state to state.

American Standard Inc.
Troup Highway
Tyler, TX 75711-9010
Attention: Manager, After Sales Support

GW-606-4800

* This warranty is for commercial usage of said equipment and not applicable when the equipment is used for a residential application. Commercial use is any application where the end purchaser uses the product for other than personal, family or household purposes.



Since Trane has a policy of continuous product and product data improvement, it reserves the right to change design and specification without notice.

Trane
6200 Troup Highway
Tyler, TX 75707-9010

A business of AmericanStandard Companies

Technical Literature - Printed in U.S.A.